

ADDENDUM

Project: Springfield OR Bishops' Storehouse

Project No.: 5418550WEC15504

Addendum No.: 1

Project Address: High Banks Road, Springfield, Oregon

Date: May 24, 2018

Owner: Corporation of the Presiding Bishop of The Church of Jesus Christ of Latter-day Saints, a Utah corporation sole

From (Architect): JRW & Associates 1152 Bond Avenue Rexburg, Idaho 83440

Instructions to Prospective Bidders:

This Addendum forms a part of the Contract Documents and modifies the original Bidding Documents and/or prior Addenda as noted below. All conditions, requirements, materials and workmanship are to be as described in the Contract Documents unless specifically stated otherwise. This Addendum consists of 22 page(s) and the attached drawing(s), Sheet(s) **LDAP 1-3**

1. Changes to prior Addenda:

- a. N/A
- b.

2. Changes to Bidding Requirements:

- a. The Bid Date has been changed to May 30, 2018 @ 2:00 p.m. Mountain Time
- b.

3. Changes to Conditions of the Contract:

- a. The Sample Contract should state 270 days for substantial completion
- b.

4. Changes to Specifications:

- a. See attached revised Section 08 0601 Hardware Group and Keying Schedules
- b. See attached Section 08 4229.23 Sliding Automatic Entrances
- c. See attached Section 12 9313 Bicycle Racks
- d. Include \$65,000 allowance for unseen site conditions Section 31 2316
- e. Include \$35,000 allowance for power utility service not described in Contract Documents
- f. Section 26 4301 Surge suppression devices by Siemens Energy and Automation are acceptable to bid
- g. Aluminum Store Front, Windows and Sliding Entrances shall be Dark Bronze finish
- h. Metal Roofing Panels over dumpster enclosure shall be 24 ga. snap seam with 20 year finish warrantee

5. Changes to Drawings:

- a. See attached LDAP drawings from Branch Engineering
- b. Detail C/SD202 provide a 12"wide x 8"deep concrete mowstrip
- c. Refer to Structural Drawings for structure on Stair Section A304

SECTION 08 0601**HARDWARE GROUP AND KEYING SCHEDULES****PART 1 - GENERAL****1.1 SUMMARY**

- A. Includes But Not Limited To:
1. Furnish and install door hardware and keying as described in Contract Documents.

1.2 REFERENCES

- A. Definitions:
1. Builders Hardware Manufacturer's Association (BHMA) Hardware Functions:
 - a. F75 Passage Latch: Latch bolt operated by lever from either side at all times.
 - b. F76 Privacy Lock: Latch bolt operated by lever from either side. Outside lever locked by push button inside and unlocked by emergency key from outside or rotating lever from inside.
 - c. F81 Office Door Lock: Dead locking latch bolt operated by lever from either side, except when outside lever is locked by turn button in inside lever. When outside lever is locked, latch bolt is operated by key in outside lever or by rotating inside lever. Turn button must be manually rotated to unlock outside lever.
 - d. F84 Classroom Deadlock: Dead locking latch bolt operated by lever from either side, except when outside lever is locked, latch bolt is operated by key in outside lever or by rotating inside lever.
 - e. F86 Utility Space Door Lock: Dead locking latch bolt operated by key in outside lever or by rotating inside lever. Outside lever is always fixed.
 - f. F91 Store Door Lock: Deadlocking latch operated by either lever. Key in either lever locks / unlocks both levers.
 - g. F109 Entrance Lock: Turn/push button locking: Pushing and turning button disengages outside lever, requiring using of key until button is manually unlocked. Push-button locking: Pushing button disengages outside lever until unlocked by key or by turning inside lever. Disengages outside spindle from latch when locked.
 - h. E2142 Deadbolt: Dead bolt operated by key from either side. Bolt automatically dead locks when fully thrown.
 - i. E2152 Deadbolt: Dead bolt operated by key from outside and turn unit from inside. Bolt automatically dead locks when fully thrown.

1.3 DELIVERY, STORAGE, AND HANDLING

- A. Delivery And Acceptance Requirements:
1. Materials shall be delivered in original, unopened packages with labels intact.

PART 2 - HARDWARE GROUPS**2.1 STOREFRONT ENTRY DOORS**

- A. Single Doors:
1. **Group ST1:**
 - a. 1 set: Pivots.
 - b. 1 set: Weatherstrip.
 - c. 1 each: Closer.

- d. 1 each: Exit Device with dogging capability and locking cylinder.
 - e. 1 each: Pull.
 - f. 1 each: Stop.
 - g. 1 each: Sweepstrip.
 - h. 1 each: Threshold.
- B. Double Doors:
- 1. **Group ST5:**
 - a. General:
 - 1) 1 each: Threshold.
 - 2) 1 set: Weatherstrip.
 - b. Active Leaf:
 - 1) 1 set: Pivots.
 - 2) 1 each: Exit Device with dogging capability and locking cylinder.
 - 3) 1 each: Closer.
 - 4) 1 each: Pull.
 - 5) 1 each: Stop.
 - 6) 1 each: Sweepstrip.
 - c. Inactive Leaf:
 - 1) 1 set: Pivots.
 - 2) 1 each: Closer.
 - 3) 1 each: Exit Device with dogging capability.
 - 4) 1 each: Pull.
 - 5) 1 each: Stop.
 - 6) 1 each: Sweepstrip.
- C. Sliding Entry Doors:
- 1. **Group SL1:**
 - a. General:
 - 1) 1 set: Weatherstrip.
 - 2) 1 each: Automatic sliding door operator.
 - 3) 1 each: Locking Cylinder.
 - 4) 1 each: Threshold.
 - 2. **Group SL2:**
 - a. General:
 - 1) 1 set: Weatherstrip.
 - 2) 1 each: Automatic sliding door operator.
 - 3) 1 each: Threshold.

2.2 EXTERIOR DOORS

- A. Single Exterior Doors:
- 1. **Group 2C:**
 - a. 1 set: Weatherstrip.
 - b. 1 each: Closer.
 - c. 1 each: Exit Device with Exit Alarm.
 - d. 3 each: Hinges.
 - e. 1 each: Stop.
 - f. 1 each: Sweepstrip.
 - g. 1 each: Threshold.
 - 2. **Group 3:**
 - a. 1 set: Weatherstrip.
 - b. 1 each: Closer.
 - c. 3 each: Hinges.
 - d. 1 each: Lockset Function F86.
 - e. 1 each: Stop.
 - f. 1 each: Sweepstrip.
 - g. 1 each: Threshold.

2.3 INTERIOR DOORS

A. Single Interior Doors:

1. **Group 22A:**
 - a. 1 set: Smoke Gaskets.
 - b. 3 each: Hinges.
 - c. 1 each: Lockset Function F86.
 - d. 1 each: Stop.
 - e. 1 each: Threshold.
2. **Group 24B:**
 - a. 1 set: Smoke Gaskets.
 - b. 1 each: Armor Plate.
 - c. 3 each: Hinges.
 - d. 1 each: Lockset Function F81.
 - e. 1 each: Stop.
 - f. 1 each: Threshold where indicated on Contract Documents.
3. **Group 24C:**
 - a. 1 set: Smoke Gaskets.
 - b. 1 each: Closer.
 - c. 1 each: Kickplate.
 - d. 3 each: Hinges.
 - e. 1 each: Lockset Function F81.
 - f. 1 each: Stop.
 - g. 1 each: Threshold where indicated on Contract Documents
4. **Group 25A:**
 - a. 1 set: Smoke Gaskets.
 - b. 1 each: Closer.
 - c. 3 each: Hinges.
 - d. 1 each: Lockset Function F81.
 - e. 1 each: Stop.
 - f. 1 each: Threshold where indicated on Contract Drawings
5. **Group 26A:**
 - a. 1 set: Smoke Gaskets.
 - b. 1 each: Closer.
 - c. 3 each: Hinges.
 - d. 1 each: Kick Plate.
 - e. 1 each: Pull.
 - f. 1 each: Push.
 - g. 1 each: Stop.
6. **Group 28F:**
 - a. 1 set: Smoke Gaskets.
 - b. 1 each: Closer.
 - c. 3 each: Hinges.
 - d. 1 each: Pull.
 - e. 1 each: Push.
 - f. 1 each: Kick Plate.
 - g. 1 each: Stop.
 - h. 1 each: Threshold where indicated on Contract Drawings

2.4 MISCELLANEOUS DOORS

A. Interior Double Rigid Traffic Doors:

1. **Group 60A:**
 - a. General: (See Section 08 3819):
 - 1) 1 each: Chain.
 - 2) 1 each: Gaskets.
 - 3) 2 each: Hinges.
 - 4) 1 each: Padlock.
 - 5) 1 each: Threshold.

- 6) 1 each: Vision Panel.

PART 3 - KEYING SCHEDULE for FINISH HARDWARE

3.1 KEYING SCHEDULE

A. Keying Schedules:

1. Bishop Storehouse Keying Schedule:

- a. General access Storage Rooms, general access Custodian Room, Offices, Mechanical and Utility Rooms, Serving Area (Institute), Secretary, and Workroom:

Key	Stamped	Amount	Remarks
AA	AA	4	
AA1	SH MGR	2	
XAA2	SH GEN	4	These locks will also be opened by AA1, AA5, XAA7, XAA8, and XAA9 keys.
XAA3	DP	4	These locks will also be opened by AA1 Key.
XAA4	SHED	2	
AA5	EMP DIR	2	
XAA6	E GEN	4	These locks will also be opened by AA5 keys.
XAA7	E OFF 1	2	These locks will also be opened by AA5 keys.
XAA8	E OFF 2	2	These locks will also be opened by AA5 keys.
XAA9	E OFF 3	2	These locks will also be opened by AA5 keys.
AA10	FS DIR	2	
XAA11	F GEN	4	These locks will also be opened by AA10, XAA12, and XAA13 keys.
XAA12	F OFF 1	2	These locks will also be opened by AA10 keys.
XAA13	F OFF 2	2	These locks will also be opened by AA10 keys.
XAA14	M GEN	4	These locks will also be opened by AA15 and XAA16 keys.
AA15	MP	2	Future (Delete 'Future' if Mission Office Module is included)
XAA16	M OFF 1	2	Future - These locks will also be opened by AA15 keys.
XAA17	TEL	2	These locks will also be opened by AA1, AA5, AA10, and AA15 keys.
XAA18	ROOF	2	These locks will also be opened by AA1 Key.
AA19	FMM	2	Future (Delete 'Future' if Facilities Management Office Module is included)
XAA20	FM ENT	2	Future - These locks will also be opened by AA19 keys.
XAA21	ENT	2	Future - These locks will be opened by XAA11, AA19, and XAA20. Door opened by key only, but remains locked.
X1X	ENT	None	These locks will also be opened by all keys in system.

- b. Provide interior keying system that includes Master and Changekey levels. Pin locks so pins in masterkeys are two numbers minimum different between masterkeys and associated change keys.

2. Family Services Keying Schedule:

Key	Stamped	Amount	Remarks
AA3	FS MGR	2	
XAA30	FS GEN	15	These locks will also be opened by AA3 Key.
XAA31	FS OFF 1	2	These locks will also be opened by AA3 Key.
XAA32	FS OFF 2	2	These locks will also be opened by AA3 Key.
XAA33	FS OFF 3	2	These locks will also be opened by AA3 Key.
XAA34	FS OFF 4	2	These locks will also be opened by AA3 Key.
XAA35	FS OFF 5	2	These locks will also be opened by AA3 Key.
XAA36	FS OFF 6	2	These locks will also be opened by AA3 Key.
XAA37	FS OFF 7	2	These locks will also be opened by AA3 Key.
XAA38	FS OFF 8	2	These locks will also be opened by AA3 key.
XAA39	FS OFF 9	2	These locks will also be opened by AA3 key.
X1X		None	These locks will also be opened by all keys in system.

- a. Provide interior keying system that includes Master and Changekey levels. Pin locks so pins in masterkeys are two numbers minimum different between masterkeys and associated change keys.

END OF SECTION

SECTION 08 4229**SLIDING AUTOMATIC ENTRANCES****PART 1 - GENERAL****1.1 SUMMARY**

A. Includes But Not Limited To:

1. Furnish and install automatic sliding entrance door system as described in Contract Documents. Door system includes following:
 - a. Sliding door panels.
 - b. Framing.
 - c. Door operators.
 - d. Headers.
 - e. Carrier assemblies.
 - f. Roller tracks.
 - g. Sidelite panels.
 - h. Lock and activation / safety system.

B. Related Requirements:

1. Section 06 2024: Installation of locking cylinders.
2. Section 07 9213: Quality of sealants.
3. Section 08 4113: 'Aluminum-Framed Entrances And Storefront':
 - a. Participate in pre-installation conference held jointly with Section 08 4229.
 - b. Furnishing and installation of glazing for sliding automatic entrances by same glazer providing Storefront entrances. Installation requirements of this Section still apply.
 - c. Furnishing and installation of sealants for sliding automatic entrances by same providing Storefront entrances. Installation requirements of this Section still apply.
4. Section 08 7103: Furnishing of locking cylinders.
5. Section 08 8100: Quality of glass glazing.
6. Section 12 4843: 'Entrance Matting'.
7. Division 26: Power Source.

1.2 REFERENCES

A. Association Publications:

1. American Architectural Manufacturers Association (AAMA):
 - a. AAMA SFM 1-14, 'Aluminum Store Front and Entrance Manual'.
 - b. AAMA 501-15, 'Methods of Test for Exterior Walls'.
 - c. AAMA 506-11, 'Voluntary Specifications for Impact and Cycle Testing of Fenestration Products'.
 - d. AAMA 609 & 610-15, 'Cleaning and Maintenance Guide for Architecturally Finished Aluminum' (combined documents).
 - e. AAMA 611-14, 'Voluntary Standards for Anodized Architectural Aluminum'.
 - f. AAMA 701/702-11, 'Voluntary Specification for Pile Weatherstripping and Replaceable Fenestration Weatherseals'.
 - g. AAMA 800-16, 'Voluntary Specifications and Test Methods for Sealants'.
 - h. AAMA 2605-13, 'Voluntary Specification, Performance Requirements and Test Procedures for Superior Performing Organic Coatings on Aluminum Extrusions and Panels'.
2. American Association of Automatic Door Manufactures (AAADM), Cleveland, OH
www.aaadm.com:
 - a. 'Automatic Door Selection Guide'.
 - b. 'Automatic Sliding Door' Owner's Manual.
3. Glass Association of North America (GANA):
 - a. 'Glazing Manual'.

4. National Association of Architectural Metal Manufacturers (NAAMM):
 - a. Metal Finishes Manual for Architectural and Metal Products.
- B. Definitions:
1. Activation Device: Device that, when actuated, sends electrical signal to door operator to open door.
 2. Glass Surface:
 - a. Insulated glass unit:
 - 1) Surface 1: Exterior surface of outer lite.
 - 2) Surface 2: Interspace-facing surface of outer lite.
 - 3) Surface 3: Interspace-facing surface of inner lite.
 - 4) Surface 4: Interior surface of inner lite.
 - b. Monolithic glass:
 - 1) Surface 1: Exterior surface.
 - 2) Surface 2: Interior surface.
 3. Safety Device:
 - a. Device that prevents door from opening or closing, as appropriate.
- C. Reference Standards:
1. American National Standards Institute:
 - a. ANSI Z97.1-2009, 'Safety Glazing Materials Used in Buildings - Safety Performance Specifications and Methods of Test'.
 2. American National Standards Institute / Builders Hardware Manufacturers Association:
 - a. ANSI/BHMA A156.5-2014, 'Cylinders and Input Devices for Locks'.
 - b. ANSI/BHMA A156.10-2011, 'Power Operated Pedestrian Doors'.
 3. ASTM International:
 - a. ASTM B209-14, 'Standard Specification for Aluminum and Aluminum-Alloy Sheet and Plate'.
 - b. ASTM B221-14, 'Standard Specification for Aluminum and Aluminum-Alloy Extruded Bars, Rods, Wire, Profiles and Tubes'.
 - c. ASTM E283-04(2012), 'Standard Test Method for Determining Rate of Air Leakage Through Exterior Windows, Curtain Walls, and Doors Under Specified Pressure Differences Across the Specimen'.
 - d. ASTM E330/E330M-14, 'Standard Test Method for Structural Performance of Exterior Windows, Doors, Skylights and Curtain Walls by Uniform Static Air Pressure Difference'.
 - e. ASTM E331-00(2016), 'Standard Test Method for Water Penetration of Exterior Windows, Skylights, Doors, and Curtain Walls by Uniform Static Air Pressure Difference'.
 - f. ASTM E2112-07(2016), 'Standard Practice for Installation of Exterior Windows, Doors and Skylights'.
 - g. ASTM F842-14, 'Standard Test Methods for Measuring the Forced Entry Resistance of Sliding Door Assemblies, Excluding Glazing Impact'.
 4. International Building Code (IBC) (2015 or most recent edition adopted by AHJ):
 - a. Chapter 10, 'Means of Egress'.
 - b. Chapter 16, 'Structural Design'.
 - 1) Section 1609 'Wind Loads'.
 5. International Code Council / American National Standards Institute:
 - a. ICC / ANSI A117.1-2009, 'Accessible and Usable Buildings and Facilities'.
 6. National Fire Protection Association / American National Standards Institute:
 - a. NFPA 70-2014, 'National Electric Code'.
 - a. NFRC 100-2014, 'Procedure for Determining Fenestration Product U-factors'.
 - b. NFPA 101-2015, 'Life Safety Code'.
 7. Underwriters Laboratories:
 - a. UL 325, 'Door, Drapery, Gate, Louver, and Window Operators and Systems' Fifth Edition June 7, 2002 (Amended by Revision 9 November 3, 2010).

1.3 ADMINISTRATIVE REQUIREMENTS

- A. Pre-Installation Conference:
1. Participate in pre-installation conference as specified in Section 08 4113.
 2. Schedule conference one (1) week before scheduled installation of automatic sliding entrance.

3. In addition to agenda items specified in Section 01 3100, review following:
 - a. Review installation scheduling, coordination, placement of doors.
 - b. Review delivery, storage, and handling requirements.
 - c. Review installation of motion and presence sensor control device.
 - d. Review location of signage on door.
 - e. Review safety issues.

1.4 SUBMITTALS

A. Action Submittals:

1. Product Data:
 - a. Manufacturer's literature or cut sheets for specified hardware items, detailed installation diagrams and instructions.
 - b. Color and finish selections.
2. Shop Drawings:
 - a. Submit shop drawings detailing installation procedures, including layout, plans, elevations, sections, details, dimensions and placement of hardware, hardware mounting heights and attachments to other work.
 - b. Indicate field measurements.
 - c. Show wind loads and engineering for Project conditions.
 - d. Clearly mark components to identify their location in Project.

B. Informational Submittals:

1. Certificates:
 - a. Certification of compliance with ANSI A156.10 by a certified AAADM inspector after door(s) is installed and commissioned.
 - b. Installer AAADM certification.
2. Manufacturers' Instructions:
 - a. Provide Manufacturer's written installation instructions.
3. Source Quality Control Submittals:
 - a. Provide automatic entrance door assemblies through one source from single Manufacturer except Motion Sensor and Pressure Sensor.

C. Closeout Submittals:

1. Include following in Operations And Maintenance Manual specified in Section 01 7800:
 - a. Operations and Maintenance Data:
 - 1) Maintenance, adjustment, and repair instructions.
 - 2) Cleaning and maintenance instructions for finishes and performance.
 - 3) Owner's Manual.
 - b. Warranty Documentation:
 - 1) Final, executed copy of Warranty.
 - a) Storefront warranty.
 - b) Motion and presence sensors.
 - c. Record Documentation:
 - 1) Manufacturers documentation:
 - a) Manufacturer's literature or cut sheets for storefront system and for each item of hardware.
 - b) Color and finish selections.
 - c) Parts lists.

1.5 QUALITY ASSURANCE

A. Regulatory Agency Sustainability Approvals:

1. Storefront System Performance Requirements:
 - a. Provide test reports from AAMA accredited laboratories certifying performances if requested:
 - 1) Air Leakage: Meet requirements of ASTM E283.

- 2) Limit air leakage through assembly to **0.06 CFM/min/sq ft (.00003 m3/sm2)** of wall area at **6.24 PSF (300 Pa)** as measured in accordance with ASTM E283.
 - 3) Water Resistance: No water leakage when measured in accordance with ASTM E331 with static test pressure of **8PSF (384 Pa)** as defined by AAMA 501.
 - 4) Dynamic Water Resistance: No water leakage, when measured in accordance with AAMA 501 with dynamic test pressure of **8 PSF (384 Pa)**.
 - 5) Limit mullion wind load deflection of L/175 with full recovery of glazing materials, when measured in accordance with ASTM E330/E330M.
 - 6) System shall not deflect more than **1/8 inch (3 mm)** at center point, or **1/16 inch (1.58 mm)** at enter point of horizontal member, once dead load points have been established.
 - 7) System shall accommodate expansion and contraction movement due to surface temperature differential of **180 deg F (82 deg C)**.
 - 8) Seismic testing shall conform to AAMA recommended static test method for evaluating performance of curtain walls and storefront wall systems due to horizontal displacements associated with seismic movements and building sway.
2. Provide wind load and impact testing by testing laboratory when required by local codes and jurisdictions:
- 1) .

B. Qualifications: Requirements of Section 01 4301 applies, but not limited to following:

1. Manufacturer Qualifications:
 - a. Provide aluminum entrances produced by a firm experienced in manufacturing systems that are similar to those indicated for this project and that have a record of successful in service performance.
2. Fabricator Qualifications:
 - a. Provide aluminum entrances fabricated by a firm experienced in producing systems that are similar to those indicated for this Project, and that have a record of successful in service performance.
 - b. Fabricator shall have sufficient production capacity to produce components required without causing delay in progress of the Work.
3. Installer Qualifications:
 - a. Manufacturer's authorized representative who is AAADM certified and trained who has completed installations of aluminum entrances similar in design and extent to those required for this Project and whose Work has resulted in construction with record of successful in service performance.

C. Certifications:

1. Automatic sliding door system shall be certified by Manufacturer to meet performance design criteria according to following test standards.
 - a. ANSI/BHMA A156.10.
 - b. IBC Egress section.
 - c. NFPA 70: Marked for intended use.
 - d. NFPA 101: Life safety from building.
 - e. Underwriter's Laboratories 325 (UL) listed.
2. Installer:
 - a. AAADM certification.
3. Manufacturer:
 - a. Qualified manufacturer with company certificate issued by AAADM.

1.6 DELIVERY, STORAGE, AND HANDLING

A. Delivery And Acceptance Requirements:

1. Deliver all parts of door, together with hardware, in original, unopened packages with labels intact to Project at same time.

B. Storage And Handling Requirements:

1. Store in clean, dry location, indoors in Manufacturer's unopened packaging until ready for installation and in accordance with Manufacturer's instructions.

2. Stack framing components in a manner that will prevent bending and avoid significant or permanent damage.
3. Protect materials and finish from damage during storage, handling, and installation.

1.7 FIELD CONDITIONS

A. Ambient Conditions:

1. Maintain environmental conditions (temperature, humidity and ventilation) within limits recommended by manufacturer for optimum results. Do not install products under environmental conditions outside manufacturer's absolute limits.

1.8 WARRANTY

A. Manufacturer Warranty:

1. Automatic Entrance Doors:
 - a. Manufacturer's Warranty to be free of defects in material and workmanship.
 - b. Manufacturer's Warranty against deterioration or fading.
2. Motion And Presence Sensor.
 - a. Manufacturer's standard warranty.

PART 2 - PRODUCTS

2.1 ASSEMBLIES

A. Manufacturers:

1. Category Four Approved Manufacturers. See Section 01 6200 for definitions of Categories:
 - a. Besam US Inc, Monroe, NC www.besam.com.
 - b. Gildor Inc, Chino, CA www.gildor.com.
 - c. Horton Automatics, Corpus Christi, TX www.hortondoors.com.
 - d. Record-USA, Monroe, NC www.record-usa.com.
 - e. Stanley DURA-GLIDE 2000 Series sliding automatic entrance doors by Stanley Access Technologies, Farmington, CT www.stanleyaccesstechnologies.com.
 - 1) Contact Information: George Sunderland, Office (801) 838-9521, Fax (801) 566-8917 GSunderland@stanleyworks.com.

B. Description:

1. Automatic sliding entrance doors with Motion And Presence Sensor Control Device.

C. Design Criteria:

1. In addition to requirements shown or specified, comply with:
 - a. Applicable provisions of AAMA SFM 1, 'Aluminum Store Front and Entrance Manual' for design, materials, fabrication and installation of component parts.
2. Provide automatic entrance door assemblies capable of withstanding structural loads and thermal movements based on testing manufacturer's standard units in assemblies similar to those indicated for this Project.
3. Thermal Movements: Provide automatic entrance doors that allow for thermal movements resulting from the following maximum change (range) in ambient and surface temperatures by preventing buckling, opening of joints, overstressing of components, failure of joint sealants, failure of connections, and other detrimental effects. Base engineering calculation on surface temperatures of materials due to both solar heat gain and nighttime-sky heat loss.
 - a. Temperature Change (Range): 120 deg F (49 deg C), ambient; 180 deg F (82 deg C), material surfaces.
4. Operating Range: Minus 30 deg F (minus 35 deg C) to 130 deg F (54 deg C).

5. Opening-Force Requirements for Egress Doors: Not more than 50 lbf (222 N) required to manually set door in motion if power fails, and not more than 15 lbf (67 N) required to open door to minimum required width.
6. Closing-Force Requirements: Not more than 30 lbf (133 N) required to prevent door from closing.
7. Door access control activated with motion and presence sensors.
8. Electrical components, devices and accessories listed and labeled in accordance with NFPA 70.
9. Comply with authorities having jurisdiction for automatic entrance doors serving as means of egress.

D. Automatic Sliding Doors:

1. Basis of Design Product:
 - a. Basis of design for this Project is Stanley DURA-GLIDE 2000 Series sliding automatic entrance doors with fixed sidelights.
 - b. Equivalents: Category Four Approved Manufacturers: Besam, Gildor, Record (Model 5100 Series), and Horton.
2. Design Criteria:
 - a. Provide manufacturer's standard automatic entrance door assemblies including doors, sidelights, framing, headers, carrier assemblies, roller tracks, door operators, activation and safety devices, and accessories required for a complete installation.
 - b. Overhead-concealed or surface-applied, electro-mechanical, microprocessor-controlled, sliding door operator.
 - c. Aluminum doors and frames with sidelite and active door leaves.
3. Materials:
 - a. Aluminum: Alloy and temper recommended by manufacturer for type of use and finish indicated.
 - b. Headers, stiles, rails, and frames: 6063-T6.
 - c. Thresholds: 6063-T6.
 - d. Extruded Bars, Rods, Profiles, and Tubes: ASTM B221.
 - e. Sheet and Plate: ASTM B209.
4. Sealant:
 - a. Structural Sealant meeting requirements of ASTM C1184 for fabrication within storefront system:
 - 1) Permanently elastic, non-shrinking, and non-migrating type for joint size and movement.
 - 2) Single-component neutral-curing silicone formulation compatible with system components specifically formulated and tested for use as structural sealant and approved by structural-sealant manufacturer for use in aluminum-framed systems indicated.
 - 3) Color: Black.
 - b. Joint Sealants used at perimeter of storefront framing system: Elastomeric Sealant as specified in Section 07 9213.
5. Door Assemblies:
 - a. Bi Parting sliding doors:
 - 1) Configuration: Two sliding leaves and two full sidelights.
 - 2) Traffic Pattern: Two-way.
 - 3) Emergency Breakaway Capability: Sliding leaves only.
 - 4) Mounting: Between jambs.
6. Components:
 - a. Framing Members:
 - 1) Manufacturer's standard extruded aluminum reinforced as required to support imposed loads:
 - a) Nominal Size: 1-3/4 inch (45 mm) by 4-1/2 inch (115 mm).
 - b) Concealed Fastening: Framing shall incorporate a concealed fastening pocket, and continuous flush insert cover, extending full length of each framing member.
 - b. Stile and Rail Doors and Sidelites:
 - 1) Manufacturer's standard 1-3/4 inch (45 mm) thick glazed doors with extruded-aluminum tubular stile and rail members. Incorporate concealed tie-rods that span full length of top and bottom rails or mechanically fasten corners with reinforcing brackets that are welded.
 - a) Glazing Stops and Gaskets: Snap-on, extruded-security aluminum stops and preformed gaskets.

- b) Stile Design: Medium; 3-1/2 inch (89 mm) nominal width.
 - c) Bottom Rail Design: Minimum 10 inch (254 mm) nominal height.
 - d) Muntin Bars: Horizontal tubular rail member for each door; 2 inch (50 mm) nominal width.
- c. Glazing:
- 1) Glass material: ANSI Z97.1 and CPSC 16 CFR 1201 for Category II materials, 1/4 inch (6.4 mm) thick, clear, fully tempered as specified in Section 08 8100 'Glass Glazing'.
- d. Headers:
- 1) Fabricated from extruded aluminum and extending full width of automatic entrance door units to conceal door operators, carrier assemblies, and roller tracks. Provide hinged or removable access panels for service and adjustment of door operators and controls. Secure panels to prevent unauthorized access:
 - a) Mounting: Concealed, with one side of header flush with framing.
 - b) Capacity: Capable of supporting doors up to 220 lbs (100 kg) per leaf over spans up to 14 feet (4.267 mm) without intermediate supports.
- e. Carrier Assemblies and Overhead Roller Tracks:
- 1) Manufacturer's standard carrier assembly that allows vertical adjustment of at least 1/8 inch (3 mm); consisting of urethane with precision steel lubricated ball-bearing wheels, operating on a continuous roller track.
 - 2) Support doors from carrier assembly by 2 inch (50 mm) diameter anti-riser wheels with factory adjusted cantilever and pivot assembly.
 - 3) Minimum two ball-bearing roller wheels and two anti-rise rollers for each active leaf. Minimum load wheel diameter shall be 2-1/2 inch (64 mm).
- f. Thresholds:
- 1) Manufacturer's standard thresholds:
 - a) Half-Saddle Threshold: Continuous 4-1/2 inch (115 mm) wide threshold – one side tapered extrusion (exterior). Coordinate with Retail Vestibule floor mat framing as specified in Section 12 4843.
 - b) Thresholds to conform to details and requirements for code compliance and handicap accessibility requirements.
- g. Fasteners and Accessories:
- 1) Manufacturer's standard corrosion-resistant, non-staining, non-bleeding fasteners and accessories compatible with adjacent materials.
7. Door Operators:
- a. Provide door operators of size recommended by manufacturer for door size, weight, and movement; for condition of exposure; and for long-term, operation under normal traffic load for type of occupancy indicated.
 - b. Electromechanical Operators: Self-contained overhead unit powered by a minimum of 1/4 horsepower, permanent-magnet DC motor with gear reduction drive, microprocessor controller; and encoder.
 - 1) Operation: Power opening and power closing.
 - 2) Features:
 - a) Adjustable opening and closing speeds.
 - b) Adjustable back-check and latching.
 - c) Adjustable braking.
 - d) Adjustable hold-open time between 0 and 30 seconds.
 - e) Obstruction recycle.
 - f) On/Off switch to control electric power to operator.
 - g) Energy conservation switch that reduces door-opening width.
 - h) Closed loop speed control with active braking and acceleration.
 - i) Variable obstruction recycle time delay.
 - j) Self adjusting stop position.
 - k) Self adjusting closing compression force.
 - l) Optional Switch to open/Switch to close operation.
 - 3) Mounting: Concealed.
 - 4) Drive System: Synchronous belt type.
 - c. Electrical Service to door operators shall be provided under Division 26 Electrical. Minimum service to be 120 VAC, 5 amps.
8. Electrical Controls:
- a. Electrical Control System:

- 1) Electrical control system shall include microprocessor controller and position encoder. Encoder shall monitor revolutions of operator shaft and send signals to microprocessor controller to define door position and speed.
- 2) Systems utilizing external magnets and magnetic switches are not acceptable.
- 3) Single controller shall be capable of controlling up to 2 operators per entrance system.
- b. Life Cycle Data Counter:
 - 1) Microprocessor control shall incorporate non-re-settable counter to track door operation cycles.
- c. Controller Protection:
 - 1) Microprocessor controller shall incorporate following features to ensure trouble free operation:
 - a) Automatic Reset Upon Power Up.
 - b) Main Fuse Protection.
 - c) Electronic Surge Protection.
 - d) Internal Power Supply Protection.
 - e) Resettable sensor supply fuse protection.
 - f) Motor Protection, over-current protection.
- d. Soft Start/Stop:
 - 1) "Soft-start" "soft-stop" motor driving circuit shall be provided for smooth normal opening and recycling.
- e. Obstruction Recycle:
 - 1) Provide system to recycle sliding panels when obstruction is encountered during closing cycle. If obstruction is detected, system shall search for that object on next closing cycle by reducing door closing speed prior to previously encountered obstruction location, and will continue to close in check speed until doors are fully closed, at which time doors will reset to normal speed. If obstruction is encountered again, door will come to full stop. Doors shall remain stopped until obstruction is removed and operate signal is given, resetting door to normal operation.
- f. Programmable Controller:
 - 1) Microprocessor controller shall be programmable and shall be designed for connection to local configuration tool. Local configuration tool shall be software driven and shall be utilized via Palm® handheld interface. Following parameters may be adjusted via configuration tool.
 - a) Operating speeds and forces as required to meet ANSI/BHMA A156.10.
 - b) Adjustable and variable features as specified in 2.05, B., 2.
 - c) Reduced opening position.
 - d) Firmware update.
 - e) Trouble Shooting:
 - (1) I/O Status.
 - (2) Electrical component monitoring including parameter summary.
 - f) Software for local configuration tool shall be available as a free download from the sliding automatic entrance manufacturer's internet site.
9. Activation and Safety Devices:
 - a. Motion Sensors:
 - 1) Motion sensors shall be mounted on each side of door header to detect pedestrians in activating zone, and to provide signal to open doors in accordance with ANSI/BHMA A156.10. Units shall be programmable for bi-directional or uni-directional operation and shall incorporate K-band microwave frequency to detect all motion in both directions.
 - b. Presence Sensors:
 - 1) Presence sensors shall be provided to sense people or objects in threshold safety zone in accordance with ANSI/BHMA A156.10.
 - 2) Units shall be self-contained, fully adjustable, and shall function accordingly with motion sensors provided.
 - 3) Sensor shall be enabled simultaneously with door-opening signal and shall emit an elliptical shaped infrared presence zone, centered on doorway threshold line.
 - 4) Presence sensors shall be capable of selectively retuning to adjust for objects which may enter safety zone; tuning out, or disregarding, presence of small nuisance objects and not tuning out large objects regardless of time the object is present in safety zone.
 - 5) Door shall close only after all sensors detect clear surveillance field.
 - c. Category Four Approved Product. See Section 01 6200 for definitions of Categories:

- 1) Wizard II SMR by BEA Inc, Pittsburgh, PA www.beasensors.com.
10. Hardware:
- a. Provide units in sizes and types recommended by automatic entrance door and hardware manufacturers for entrances and uses indicated.
 - b. Emergency Breakaway Feature:
 - 1) Provide release hardware that allows panel(s) to swing out in direction of egress to full 90 degrees from any position in sliding mode. Maximum force to open panel shall be 50 lbf (222 N) according to ANSI/BHMA A156.10. Interrupt powered operation of panel operator while in breakaway mode:
 - a) Emergency breakaway feature shall include at least one adjustable detent device mounted in top of each breakaway panel to control panel breakaway force.
 - b) Limit Arms: Limit arms shall be provided to control swing of non-sliding panels on break-out; swing shall not exceed 90 degrees.
 - c. Deadlocks:
 - 1) Manufacturer's standard deadbolt operated by dummy exterior cylinder and interior thumb turn; with minimum 1 inch (25 mm) long throw bolt; ANSI/BHMA A156.5, Grade 1.
 - a) Hook Latch: Laminated-steel hook, mortise type, BHMA A156.5, Grade 1.
 - b) Two-Point Locking for bi-parting entrances: Provide locking system that incorporates device in stile of active door leaves that automatically extends flush bolt into overhead carrier assembly.
 - d. Control Switch:
 - 1) Provide manufacturer's standard header mounted rocker switches to allow for full control of automatic entrance door. Controls to include, but are not limited to:
 - a) Power On/Off.
 - b) Reduced Opening.
 - c) Open/Closed/Automatic.
 - e. Sliding Weather Stripping:
 - 1) Manufacturer's standard replaceable components complying with AAMA 701; made of wool, polypropylene, or nylon woven pile with nylon-fabric or aluminum-strip backing.
 - f. Weather Sweeps:
 - 1) Manufacturer's standard adjustable nylon brush sweep mounted to underside of door bottom.
- E. Fabrication:
1. Factory fabricates automatic entrance door assembly components to designs, sizes, and thickness indicated and to comply with indicated standards.
 - a. Form aluminum shapes before finishing.
 - b. Use concealed fasteners to greatest extent possible.
 - 1) Where fasteners are subject to loosening or turning out from thermal and structural movements, wind loads, or vibration, use self-locking devices.
 - 2) Reinforce members as required to receive fastener threads.
 2. Framing:
 - a. Provide automatic entrance doors as prefabricated assemblies:
 - 1) Fabricate tubular and channel frame assemblies with manufacturer's standard mechanical or welded joints. Provide sub-frames and reinforcement as required for a complete system to support required loads.
 - 2) Perform fabrication operations in manner that prevents damage to exposed finish surfaces.
 - 3) Form profiles that are sharp, straight, and free of defects or deformations.
 - 4) Prepare components to receive concealed fasteners and anchor and connection devices.
 - 5) Fabricate components with accurately fitted joints with ends coped or mitered to produce hairline joints free of burrs and distortion.
 3. Doors:
 - a. Factory fabricated and assembled in profiles indicated.
 - b. Reinforce as required to support imposed loads and for installing hardware.
 4. Door Operators: Factory fabricated and installed in headers, including adjusting and testing.
 5. Glazing: Fabricate framing with minimum glazing edge clearances for thickness and type of glazing indicated.

6. Hardware: Factory install hardware to the greatest extent possible; remove only as required for final finishing operation and for delivery to and installation at Project site.
7. Mortise in manner to give maximum hardware-door connection strength and neatness of appearance. Adequately reinforce with backplates or rivnuts to hold pivots and closers.

F. Factory Finish:

1. Fluorocarbon Carbon: comply with AAMA 2605:
 - a. Polyvinylidene Fluoride (PVDF) Resin-base finish (Kynar 500 or Hylar 5000) containing seventy (70) percent minimum (PVDF) in resin portion of formula and providing pencil hardness of 3H. Thermo-cured two coat system consisting of corrosion inhibiting epoxy primer and topcoat factory applied over properly pre-treated metal.
 - b. Color as selected by Architect from Storefront Manufacturer's standard colors:
 - 1) Finish to match storefront as specified in Section 08 4113.
 - c. Category Four Approved Manufacturers. See Section 01 6200 for definitions of Categories:
 - 1) BASF.
 - 2) PPG Industries, Inc.
 - 3) Valspar Corporation.

PART 3 - EXECUTION

3.1 INSTALLERS

- A. Performance Standard Installers: See Section 01 6200 for definitions of Categories. See Section 01 4301 and 'Quality Assurance' in Part 1 'General' for Installer Qualifications of this specification:
1. General Contractor responsible for Installer(s), verification of qualifications, and performance. Contact Approved Manufacturer's Representative specified in Part 2 'Products' of this specification for potential installers if desired.

3.2 EXAMINATION

- A. Verification Of Conditions:
1. Verify that substrate conditions are acceptable for product installation in accordance with Manufacturer's instructions.
 2. Examine conditions for compliance with requirements for installation tolerances, header support and other conditions affecting performance of automatic entrance doors.
 3. Verify floor is level across entire width of automatic door opening.
 4. Verify sill conditions are level and/or sloped away from openings as specified.
 5. Verify wall framing is dry, clean, sound, and free of voids and offsets, construction debris, sharp edges or anything that will prevent a successful installation of storefront system.
 6. Notify Architect of unsuitable conditions in writing.
 - a. Correct unsatisfactory conditions before proceeding.
 - b. Commencement of Work by installer is considered acceptance of substrate.
- B. Evaluation And Assessment:
1. Verify actual openings with field measurements for automatic door assemblies and record same on shop drawings.
 2. Coordinate field measurements and fabrication schedule with construction progress to avoid construction delays.

3.3 PREPARATION

- A. Coordinate layout and installation of electrical rough-in for connections to automatic entrance door power supplies and security access control requirements.

3.4 INSTALLATION

- A. General:
1. Installation shall meet or exceed all applicable federal, state and local requirements, referenced standards and conform to codes and ordinances of authorities having jurisdiction.
 2. All installation shall be in accordance with manufacturer's published recommendations and in accordance with approved shop drawings.
 3. Do not install damaged components. Fit frame joints tight, free of burrs and distortion. Rigidly secure non-movement joints.
 4. Isolate metal surfaces in contact with incompatible metal or corrosive substrates, including wood, by applying sealer tape to prevent electrolytic action.
- B. Entrances:
1. Install automatic entrance doors plumb and true in alignment with established lines and grades without warp or rack of framing members and doors. Anchor securely in place.
 - a. Sidelites: Line up horizontal rail in sidelite with door rail.
 - b. Install surface-mounted hardware using concealed fasteners.
 - c. Set headers, carrier assemblies, tracks, operating brackets and guides level and true to location with anchorage for permanent support.
- C. Thresholds:
1. Accurately cut thresholds to fit profile of storefront frame. Bed thresholds in specified sealant at contact points with floor and make watertight.
 2. Coordinate with Retail Vestibule floor mat framing as specified in Section 12 4843.
- D. Door Operators:
1. Connect door operators to electrical power distribution system.
- E. System Integration:
1. Integrate automatic sliding entrance doors with other systems to provide complete working system.
 2. Provide electrical interface control capability for operation of sliding automatic entrances on doors with electrical locking.
 3. Provide electrical interface to deactivate power door operators on activation of fire alarm system.
- F. Sealants:
1. Apply in accordance with Section 07 9213 'Elastomeric Joint Sealant' requirements.
 2. Caulk joints between frames and walls, both interior and exterior to provide weather tight installation.
- G. Glazing Characteristics:
1. Exterior Doors And Storefront:
 - a. Clear interior pane and Clear exterior pane with Low E treatment on surface 2.
 2. Interior Doors And Vestibules:
 - a. Clear.
- H. Signage:
1. See ANSI / BHMA A156.10 signage recommendations and coordinate with Project Manager.
 2. Exterior Doors And Storefront:
 - a. Provide signage on door glazing of automatic doors to designate ENTRANCE.
 3. Interior Doors And Vestibules:
 - a. Provide signage on door glazing of automatic doors to designate EXIT.

3.5 FIELD QUALITY CONTROL

- A. Field Tests:
1. Perform tests recommended and required by manufacturer to verify required performance of sliding automatic entrances.

2. Testing and inspection by trained installer to test and inspect each automatic entrance door to determine compliance of installed systems with applicable standards.
- B. Field Inspections:
1. Verify correct position of decals and labels so that they are easily readable.
 2. Make sure doorway, approaches and floor guides are clean and free of debris that could interfere with proper door operation.
 3. Check door mats are in correct position, with no corners turned up.
 4. Ensure guide rails are securely in place.
 5. Ensure door is securely in position.
 6. Make all necessary final adjustments to attain normal operation of each door and its mechanical hardware.
- C. Non-Conforming Work:: Non-conforming work as covered in the General Conditions applies, but is not limited to the following:
1. Correct any work found defective or not complying with contract document requirements including removal and replacement of glass that has been broken, chipped, cracked, abraded, or damaged during construction period at no additional cost to the Owner.

3.6 ADJUSTING

- A. Adjust doors for proper operation after glazing entry. After repeated operation of completed installation, re-adjust door operators and controls for optimum operating condition and safety.
- B. Adjust door operators, controls and hardware for smooth and safe operation, for weathertight closure and complying with requirements in ANSI/BHMA A156.10.

3.7 PROTECTION

- A. During Installation:
1. Installer's Responsibility:
 - a. During installation, all adjacent work shall be protected from damage.
- B. After Installation:
1. General Contractor's Responsibility:
 - a. Institute protective measures required throughout remainder of construction period to ensure that aluminum entrances will be without damage or deterioration, other than normal weathering, at time of acceptance.

3.8 CLEANING

- A. General:
1. Installer's Responsibility:
 - a. Follow Manufacturer's written recommendations for cleaning and maintenance or guidelines of AAMA Publications 609 and 610 'Cleaning and Maintenance Guide for Architecturally Finished Aluminum' (combined documents). Avoid damaging protective coatings and finishes.
 - b. Clean glass and aluminum surfaces, inside and out, promptly after installation. Remove excess glazing and sealant compounds, dirt, and other substances. Exercise care to avoid damage to coatings.
 - c. Remove nonpermanent labels, protective films, and clean surfaces following recommended procedures.
- B. Waste Management:
1. Upon completion and verification of performance of installation, remove surplus materials, excess materials, rubbish, tools and equipment.

3.9 CLOSE-OUT ACTIVITIES

- A. Training:
 - 1. Before Substantial Completion, explain and review Daily Safety Check Procedure to personnel designated by Owner.
 - a. Access to AAADM Daily Safety Check videos.

END OF SECTION

SECTION 12 9313**BICYCLE RACKS****PART 1 - GENERAL****1.1 SUMMARY**

- A. Products Furnished But Not Installed Under This Section:
 - 1. Bicycle racks.
- B. Related Requirements:
 - 1. Section 03 3053: 'Miscellaneous Cast-In-Place Concrete' for installation.

1.2 REFERENCES

- A. Reference Standards:
 - 1. ASTM International:
 - a. ASTM A53/A53M-12, 'Standard Specification for Pipe, Steel, Black and Hot-Dipped, Zinc-Coated, Welded and Seamless'.
 - b. ASTM A123 /A123M-13, 'Standard Specification for Zinc (Hot-Dip Galvanized) Coatings on Iron and Steel Products'.
 - c. ASTM A500/A500M-13, 'Standard Specification for Cold-Formed Welded and Seamless Carbon Steel Structural Tubing in Rounds and Shapes'.
 - d. ASTM D3451-06(2012), 'Standard Guide for Testing Coating Powders and Powder Coatings'.
 - e. ASTM D7378-10, 'Standard Practice for Measurement of Thickness of Applied Coating Powders to Predict Cured Thickness'.
 - f. ASTM D7803-12, 'Standard Practice for Preparation of Zinc (Hot-Dip Galvanized) Coated Iron and Steel Product and Hardware Surfaces for Powder Coating'.
- B. Reference Standard:
 - 1. ASTM International:
 - a. ASTM A312/A312M-15, 'Standard Specification for Seamless, Welded, and Heavily Cold Worked Austenitic Stainless Steel Pipes'.

1.3 SUBMITTALS

- A. Informational Submittals:
 - 1. Manufacturers' Instruction:
 - a. Provide installation instruction including mounting and tolerances.

1.4 DELIVERY, STORAGE, AND HANDLING

- A. Delivery And Acceptance Requirements:
 - 1. Materials shall be delivered in original, unopened packages with labels intact.
- B. Storage And Handling Requirements:
 - 1. Protect racks and finish from damage during handling and installation.

PART 2 - PRODUCTS**2.1 MANUFACTURERS**

- A. Type One Acceptable Manufacturers:
1. Columbia Cascade, Portland, OR www.timberform.com.
 2. Creative Pipe Inc, Hermosa Beach, CA www.creativepipe.com.
 3. Huntco Supply LLC, Portland, OR www.huntco.com.
 4. Madrax, Wannakee, WI www.madrax.com.
 5. Equal as approved by Architect before bidding. See Section 01 6200.

2.2 MANUFACTURED UNITS

- A. Bicycle Rack:
1. Design: Serpentine Style:
 2. Steel Pipe: ASTM A53 Type F or Type S, Schedule 40.
 3. Mounting: In-Ground.
 4. Bicycle Capacity: As determined by Architect to conform to project requirements.
- B. Fabrication:
1. Cast-in-place model fabricated from 2-3/8 inch (60.3 mm) outside diameter, 0.154 inch (3.9 mm) wall, Schedule 40 steel pipe.
- C. Factory Finish:
1. Powder coated after complete fabrication:
 - a. Preparation: Steel must be free of any scale, paint, varnish, grease, or rust.
 - b. Sandblast: SSPC 5/NACE 'white finish'.
 - c. Primed: small molecule zinc rich epoxy primer.
 - d. Apply powder coating: Super Durable TGIC polyester top coat.
 2. Color: As selected by Owner from Manufacturers standard colors.
- D. Type One Acceptable Products:
1. Original CycLoops by Columbia Cascade.
 2. Thunderbolt Series by Creative Pipe.
 3. BR Series by Huntco Supply.
 4. Heavy Duty Winder by Madrax.

PART 3 - EXECUTION**END OF SECTION**

- d. Detail P/A503 is not used
- e. Door 114A should have hardware group 3
- f. Window frames shall be thermally broken with a 1" insulated pane with .45 U value
- g. Sheet E604: Lighting fixture package as submitted by Northern Illumination Company, LLC; Portland, OR. is acceptable to bid.

End of Addendum

CHURCH OF JESUS CHRIST OF LATTER-DAY SAINTS

LAND & DRAINAGE ALTERATION PLAN SPRINGFIELD, LANE COUNTY, OREGON

DRAWING INDEX	
SHEET	TITLE
EC1	COVER AND ESCP NOTE SHEET
EC2	CONSTRUCTION SITE MANAGEMENT PLAN SHEET
EC3	EROSION AND SEDIMENT CONTROL DETAIL SHEET

OWNER:
CORPORATION OF THE PRESIDING BISHOP OF THE CHURCH OF JESUS CHRIST OF LATTER-DAY SAINTS
50 EAST NORTH TEMPLE STREET
SALT LAKE CITY, UT 84150
CONTACT: JOHNNY WATSON
TEL: 208-359-2309

GEOTECHNICAL ENGINEER:
BRANCH ENGINEERING, INC.
310 5TH STREET
SPRINGFIELD, OR 97477
CONTACT: RONALD DERRICK, PE, GE
PHONE: 541-746-0637

ENGINEER:
BRANCH ENGINEERING, INC.
310 5TH STREET
SPRINGFIELD, OR 97477
CONTACT: DAMIEN GILBERT, P.E.
541-746-0637

SURVEYOR:
BRANCH ENGINEERING, INC.
310 5TH STREET
SPRINGFIELD, OR 97477
PHONE: 541-746-0637

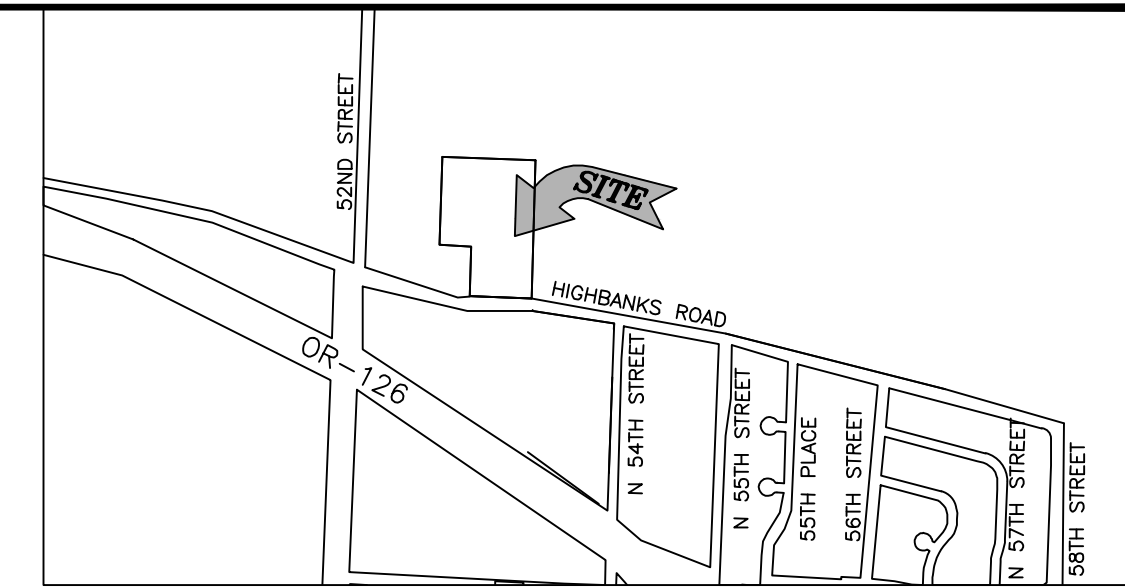

VACINITY MAP N.T.S.



310 5th Street
Springfield, OR 97477
p. 541.746.0637
www.BranchEngineering.com
Springfield OR | Albany OR



project title:

	BMPs WITH ESCP IMPLEMENTATION SCHEDULE FORM												
	YEAR	2016											
	MONTHS*	OCT	NOV	DEC	JAN	FEB	MAR	APR	MAY	JUNE	JULY	AUG	SEP
BIOBAGS		X	X	X	X	X	X	X	X	X	X	X	X
TRUCK WHEEL WASH	N/A	X	X	X	X	X	X	X	X	X	X	X	X
CHECK DAMS	N/A												
COMPOST BERM	N/A												
COMPOST BLANKETS	N/A												
COMPOST SOCKS	N/A												
CONCRETE TRUCK WASHOUT		X	X	X	X	X	X	X	X	X	X	X	X
CONSTRUCTION ENTRANCE		X	X	X	X	X	X	X	X	X	X	X	X
DEWATERING (TREATMENT LOCATION, SCHEMATIC, & SAMPLING PLAN REQUIRED)	N/A												
DRAINAGE SWALES	N/A												
EARTH DIKES (STABILIZED)	N/A												
ENERGY DISSIPATORS	N/A												
EROSION CONTROL BLANKETS & MATS (SPECIFY TYPE)	N/A												
HYDROSEEDING		X	X	X	X	X	X	X	X	X	X	X	X
INLET PROTECTION		X	X	X	X	X	X	X	X	X	X	X	X
MULCHES (SPECIFY TYPE)	N/A												
MYCORRHIZAE/BIOFERTILIZERS	N/A												
NATURAL BUFFER ZONE	N/A												
ORANGE FENCING (PROTECTING SENSITIVE/PRESERVED AREAS)		X	X	X	X	X	X	X	X	X	X	X	X
OUTLET PROTECTION	N/A												
PERMANENT BEEDING AND PLANTING												X	X
PIPE SLOPE DRAINS	N/A												
PLASTIC SHEETING		X	X	X	X	X	X	X	X	X	X	X	X
PRESERVE EXISTING VEGETATION	N/A												
SEDIMENT FENCING		X	X	X	X	X	X	X	X	X	X	X	X
SEDIMENT BARRIER	N/A												
SEDIMENT TRAP	N/A												
SODDING	N/A												
SOIL TACKIFIERS	N/A												
STORM DRAIN INLET PROTECTION	N/A												
STRAW WATTLES (OR OTHER MATERIALS)	N/A												
TEMPORARY DIVERSION DIKES	N/A												
TEMPORARY OR PERMANENT SEDIMENTATION BASINS	N/A												
TEMPORARY SEEDING AND PLANTING	N/A												
TREATMENT SYSTEM (O & M PLAN REQUIRED)	N/A												
UNPAVED ROADS GRAVELED OR OTHER BMP ON THE ROAD	N/A												
VEGETATIVE BUFFER STRIPS	N/A												

DEQ GENERAL NOTES

- HOLD A PRE-CONSTRUCTION MEETING OF PROJECT CONSTRUCTION PERSONNEL THAT INCLUDES THE INSPECTOR TO DISCUSS EROSION AND SEDIMENT CONTROL MEASURES AND CONSTRUCTION LIMITS. (SCHEDULE A.8.c.i.(3))
- ALL INSPECTIONS MUST BE MADE IN ACCORDANCE WITH DEQ 1200-C PERMIT REQUIREMENTS. (SCHEDULE A.12.b AND SCHEDULE B.1)
- INSPECTION LOGS MUST BE KEPT IN ACCORDANCE WITH DEQ'S 1200-C PERMIT REQUIREMENTS. (SCHEDULE B.1.c AND B.2)
- RETAIN A COPY OF THE ESCP AND ALL REVISIONS ON SITE AND MAKE IT AVAILABLE ON REQUEST TO DEQ, OR THE LOCAL MUNICIPALITY, DURING INACTIVE PERIODS OF GREATER THAN SEVEN (7) CONSECUTIVE CALENDAR DAYS. THE ABOVE RECORDS MUST BE RETAINED BY THE PERMIT REGISTRANT BUT DO NOT NEED TO BE AT THE CONSTRUCTION SITE. (SCHEDULE B.2.c)
- ALL PERMIT REGISTRANTS MUST IMPLEMENT THE ESCP. FAILURE TO IMPLEMENT ANY OF THE CONTROL MEASURES OR PRACTICES DESCRIBED IN THE ESCP IS A VIOLATION OF THE PERMIT. (SCHEDULE A.8.a)
- THE ESCP MUST BE ACCURATE AND REFLECT SITE CONDITIONS. (SCHEDULE A.12.c.i)
- SUBMISSION OF ALL ESCP REVISIONS IS NOT REQUIRED; SUBMITTAL OF THE ESCP REVISIONS IS ONLY UNDER SPECIFIC CONDITIONS. SUBMIT ALL NECESSARY REVISION TO DEQ OR AGENT WITHIN 10 DAYS. (SCHEDULE A.12.c.ii AND v)
- PHASE CLEARING AND GRADING TO THE MAXIMUM EXTENT PRACTICAL TO PREVENT EXPOSED INACTIVE AREAS FROM BECOMING A SOURCE OF EROSION. (SCHEDULE A.7.a.iii)
- IDENTIFY, MARK, AND PROTECT (BY CONSTRUCTION FENCING OR OTHER MEANS) CRITICAL RIPARIAN AREAS AND VEGETATION INCLUDING IMPORTANT TREES AND ASSOCIATED ROOTING ZONES, AND VEGETATION AREAS TO BE PRESERVED. IDENTIFY VEGETATIVE BUFFER ZONES BETWEEN THE SITE AND SENSITIVE AREAS (E.G., WETLANDS), AND OTHER AREAS TO BE PRESERVED, ESPECIALLY IN PERIMETER AREAS. (SCHEDULE A.8.c.i.(1) & (2))
- PRESERVE EXISTING VEGETATION WHEN PRACTICAL AND RE-VEGETATE OPEN AREAS. RE-VEGETATE OPEN AREAS WHEN PRACTICAL BEFORE AND AFTER GRADING OR CONSTRUCTION. IDENTIFY THE TYPE OF VEGETATIVE SEED MIX USED. (SCHEDULE A.7.a.v)
- MAINTAIN AND DELINEATE ANY EXISTING NATURAL BUFFER WITHIN THE 50-FOOT OF WATERS OF THE STATE. (SCHEDULE A.7.b.i AND (2)(a)(b))
- INSTALL PERIMETER SEDIMENT CONTROL, INCLUDING STORM DRAIN INLET PROTECTION AS WELL AS ALL SEDIMENT BASINS, TRAPS, AND BARRIERS PRIOR TO LAND DISTURBANCE. (SCHEDULE A.8.c.i.(5))
- CONTROL BOTH PEAK FLOW RATES AND TOTAL STORMWATER VOLUME, TO MINIMIZE EROSION AT OUTLETS AND DOWNSTREAM CHANNELS AND STREAMBANKS. (SCHEDULE A.7.c)
- CONTROL SEDIMENT AS NEEDED ALONG THE SITE PERIMETER AND AT ALL OPERATIONAL INTERNAL STORM DRAIN INLETS AT ALL TIMES DURING CONSTRUCTION, BOTH INTERNALLY AND AT THE SITE BOUNDARY. (SCHEDULE A.7.d.i)
- ESTABLISH CONCRETE TRUCK AND OTHER CONCRETE EQUIPMENT WASHOUT AREAS BEFORE BEGINNING CONCRETE WORK. (SCHEDULE A.8.c.i.(6))
- APPLY TEMPORARY AND/OR PERMANENT SOIL STABILIZATION MEASURES IMMEDIATELY ON ALL DISTURBED AREAS AS GRADING PROGRESSES. TEMPORARY OR PERMANENT STABILIZATION MEASURES ARE NOT REQUIRED FOR AREAS THAT ARE INTENDED TO BE LEFT UNGRADED, SUCH AS DIRT ACCESS ROADS OR UTILITY POLE PADS. (SCHEDULE A.8.c.i.(3))
- ESTABLISH MATERIAL AND WASTE STORAGE AREAS, AND OTHER NON-STORMWATER CONTROLS. (SCHEDULE A.8.c.i.(7))
- PREVENT TRACKING OF SEDIMENT ONTO PUBLIC OR PRIVATE ROADS USING BMPs SUCH AS: CONSTRUCTION ENTRANCE, GRAVELED (OR PAVED) EXITS AND PARKING AREAS, GRAVEL ALL UNPAVED ROADS LOCATED ONSITE, OR USE AN EXIT TIRE WASH. THESE BMPs MUST BE IN PLACE PRIOR TO LAND-DISTURBING ACTIVITIES. (SCHEDULE A.7.d.ii AND A.8.c.i.(4))
- WHEN TRUCKING SATURATED SOILS FROM THE SITE, EITHER USE WATER-TIGHT TRUCKS OR DRAIN LOADS ON SITE. (SCHEDULE A.7.d.iii)
- CONTROL PROHIBITED DISCHARGE FROM LEAVING THE CONSTRUCTION SITE, I.E., CONCRETE WASH-OUT, WASTEWATER FROM CLEANOUT OF STUCCO, PAINT AND CURING COMPOUNDS. (SCHEDULE A.6)
- USE BMPs TO PREVENT OR MINIMIZE STORMWATER EXPOSURE TO POLLUTANTS FROM SPILLS, VEHICLE AND EQUIPMENT FUELING, MAINTENANCE, AND STORAGE. OTHER CLEANING AND MAINTENANCE ACTIVITIES, AND WASTE HANDLING ACTIVITIES THESE POLLUTANTS INCLUDE FUEL, HYDRAULIC FLUID, AND OTHER OILS FROM VEHICLES AND MACHINERY, AS WELL AS DEBRIS, FERTILIZER, PESTICIDES, PAINTS, SOLVENTS, AND CURING COMPOUNDS AND ADHESIVES FROM CONSTRUCTION OPERATIONS. (SCHEDULE A.7.e.i.(2))
- IMPLEMENT THE FOLLOWING BMPs WHEN APPLICABLE: WRITTEN SPILL PREVENTION AND RESPONSE PROCEDURES, EMPLOYEE TRAINING ON SPILL PREVENTION AND PROPER DISPOSAL PROCEDURES, SPILL KITS IN ALL VEHICLES, REGULAR MAINTENANCE SCHEDULE FOR VEHICLES AND MACHINERY, MATERIAL DELIVERY AND STORAGE CONTROLS, TRAINING AND SIGNAGE, AND COVERED STORAGE AREAS FOR WASTE AND SUPPLIES. (SCHEDULE A.7.e.ii)
- USE WATER, SOIL-BINDING AGENT OR OTHER DUST CONTROL TECHNIQUE AS NEEDED TO AVOID WIND-BLOWN SOIL. (SCHEDULE A.7.a.ii)
- THE APPLICATION RATE OF FERTILIZERS USED TO REESTABLISH VEGETATION MUST FOLLOW MANUFACTURER'S RECOMMENDATIONS TO MINIMIZE NUTRIENT RELEASES TO SURFACE WATERS. EXERCISE CAUTION WHEN USING TIME-RELEASE FERTILIZERS WITHIN ANY WATERWAY RIPARIAN ZONE. (SCHEDULE A.9.b.iii)
- IF AN ACTIVE TREATMENT SYSTEM (FOR EXAMPLE, ELECTRO-COAGULATION, FLOCCULATION, FILTRATION, ETC.) FOR SEDIMENT OR OTHER POLLUTANT REMOVAL IS EMPLOYED, SUBMIT AN OPERATION AND MAINTENANCE PLAN (INCLUDING SYSTEM SCHEMATIC, LOCATION OF SYSTEM, LOCATION OF INLET, LOCATION OF DISCHARGE, DISCHARGE DISPERSION DEVICE DESIGN, AND A SAMPLING PLAN AND FREQUENCY) BEFORE OPERATING THE TREATMENT SYSTEM. OBTAIN PLAN APPROVAL BEFORE OPERATING THE TREATMENT SYSTEM. OPERATE AND MAINTAIN THE TREATMENT SYSTEM ACCORDING TO MANUFACTURER'S SPECIFICATIONS. (SCHEDULE A.9.d)
- TEMPORARILY STABILIZE SOILS AT THE END OF THE SHIFT BEFORE HOLIDAYS AND WEEKENDS, IF NEEDED; THE REGISTRANT IS RESPONSIBLE FOR ENSURING THAT SOILS ARE STABLE DURING RAIN EVENTS AT ALL TIMES OF THE YEAR. (SCHEDULE A.7.a)
- AS NEEDED BASED ON WEATHER CONDITIONS, AT THE END OF EACH WORKDAY SOIL STOCKPILES MUST BE STABILIZED OR COVERED, OR OTHER BMPs MUST BE IMPLEMENTED TO PREVENT DISCHARGES TO SURFACE WATERS OR CONVEYANCE SYSTEMS LEADING TO SURFACE WATERS. (SCHEDULE A.7.e.i.(2))
- CONSTRUCTION ACTIVITIES MUST AVOID OR MINIMIZE EXCAVATION AND CREATION OF BARE GROUND DURING WET WEATHER. (SCHEDULE A.7.a.i)
- SEDIMENT FENCE: REMOVE TRAPPED SEDIMENT BEFORE IT REACHES ONE THIRD OF THE ABOVE GROUND FENCE HEIGHT AND BEFORE FENCE REMOVAL. (SCHEDULE A.9.c.i)
- OTHER SEDIMENT BARRIERS (SUCH AS BILOBAGS): REMOVE SEDIMENT BEFORE IT REACHES TWO INCHES DEPTH ABOVE GROUND HEIGHT, AND BEFORE BMP REMOVAL. (SCHEDULE A.9.c.i)
- CATCH BASINS: CLEAN BEFORE RETENTION CAPACITY HAS BEEN REDUCED BY FIFTY PERCENT. SEDIMENT BASINS AND SEDIMENT TRAPS: REMOVE TRAPPED SEDIMENTS BEFORE DESIGN CAPACITY HAS BEEN REDUCED BY FIFTY PERCENT AND AT COMPLETION OF PROJECT. (SCHEDULE A.9.c.ii & iv)
- WITHIN 24 HOURS, SIGNIFICANT SEDIMENT THAT HAS LEFT THE CONSTRUCTION SITE, MUST BE REMEDIATED. INVESTIGATE THE CAUSE OF THE SEDIMENT RELEASE AND IMPLEMENT STEPS TO PREVENT A RECURRENCE OF THE DISCHARGE WITHIN THE SAME 24 HOURS. ANY IN-STREAM CLEAN UP OF SEDIMENT SHALL BE PERFORMED ACCORDING TO THE OREGON DIVISION OF STATE LANDS REQUIRED TIMEFRAME. (SCHEDULE A.9.b.i)
- THE INTENTIONAL WASHING OF SEDIMENT INTO STORM SEWERS OR DRAINAGEWAYS MUST NOT OCCUR. VACUUMING OR DRY SWEEPING AND MATERIAL PICKUP MUST BE USED TO CLEANUP RELEASED SEDIMENTS. (SCHEDULE A.9.b.ii)
- THE ENTIRE SITE MUST BE TEMPORARILY STABILIZED USING VEGETATION OR A HEAVY MULCH LAYER, TEMPORARY SEEDING, OR OTHER METHOD SHOULD ALL CONSTRUCTION ACTIVITIES CEASE FOR 30 DAYS OR MORE. (SCHEDULE A.7.i.i)
- PROVIDE TEMPORARY STABILIZATION FOR THAT PORTION OF THE SITE WHERE CONSTRUCTION ACTIVITIES CEASE FOR 14 DAYS OR MORE WITH A COVERING OF BLOWN STRAW AND A TACKIFIER, LOOSE STRAW, OR AN ADEQUATE COVERING OF COMPOST MULCH UNTIL WORK RESUMES ON THAT PORTION OF THE SITE. (SCHEDULE A.7.i.ii)
- DO NOT REMOVE TEMPORARY SEDIMENT CONTROL PRACTICES UNTIL PERMANENT VEGETATION OR OTHER COVER OF EXPOSED AREAS IS ESTABLISHED. ONCE CONSTRUCTION IS COMPLETE AND THE SITE IS STABILIZED, ALL TEMPORARY EROSION CONTROLS AND RETAINED SOILS MUST BE REMOVED AND DISPOSED OF PROPERLY, UNLESS DOING SO CONFLICTS WITH LOCAL REQUIREMENTS. (SCHEDULE A.8.c.iii(1) AND D.3.c.ii AND iii)

LAND AND DRAINAGE ALTERATION PROGRAM (LDAP) NOTES

- PRIOR TO ANY GROUND DISTURBANCE ON THE SITE ONE INSPECTION WITH LDAP STAFF IS REQUIRED. ISSUANCE OF THIS PLAN DOES NOT RELIEVE THE PERMIT HOLDER AND OR THE CONTRACTOR FROM ALL OTHER PERMITTING REQUIREMENTS. PRIOR TO BEGINNING CONSTRUCTION ACTIVITIES, ALL OTHER NECESSARY APPROVALS SHALL BE OBTAINED.
- THE EROSION AND SEDIMENT CONTROL MEASURES SHOWN ON THE PLAN ARE THE MINIMUM REQUIREMENTS FOR ANTICIPATED SITE CONDITIONS. DURING THE CONSTRUCTION PERIOD, THESE MEASURES SHALL BE UPGRADED AS NEEDED FOR UNEXPECTED STORM EVENTS AND TO ENSURE THAT SEDIMENT AND SEDIMENT-LADEN WATER DOES NOT LEAVE THE SITE.
- THE IMPLEMENTATION OF THE ESCP AND THE CONSTRUCTION, MAINTENANCE, REPLACEMENT, AND UPGRADE OF THE EROSION AND SEDIMENT CONTROL MEASURES IS THE RESPONSIBILITY OF THE PERMIT HOLDER AND OR THE CONTRACTOR UNTIL ALL CONSTRUCTION IS COMPLETED AND VEGETATION / LANDSCAPING IS ESTABLISHED.
- THE BOUNDARIES OF THE CLEARING LIMITS SHOWN ON THIS PLAN SHALL BE CLEARLY FLAGGED IN THE FIELD BY THE ENGINEER PRIOR TO CONSTRUCTION. DURING THE CONSTRUCTION PERIOD, NO DISTURBANCE BEYOND THE FLAGGED CLEARING LIMITS SHALL BE PERMITTED. THE FLAGGING SHALL BE MAINTAINED BY THE PERMIT HOLDER OR THE CONTRACTOR FOR THE DURATION OF CONSTRUCTION. THE EROSION AND SEDIMENT CONTROL MEASURES ON ACTIVE SITES SHALL BE INSPECTED AND MAINTAINED DAILY AND WITHIN THE 24 HOURS AFTER ANY STORM EVENT OF GREATER THAN 0.5 INCHES OF RAIN PER 24 HOUR PERIOD. MEASURES SHALL BE INSPECTED BY THE PERMIT HOLDER AND OR THE CONTRACTOR AFTER EACH RAINFALL AND AT LEAST DAILY DURING PROLONGED RAINFALL. ANY REQUIRED REPAIRS OR ADJUSTMENTS SHALL BE MADE IMMEDIATELY. THE EROSION AND SEDIMENT CONTROL MEASURES ON INACTIVE SITES SHALL BE INSPECTED A MINIMUM OF ONCE EVERY TWO (2) WEEKS OR WITHIN 48 HOURS FOLLOWING A STORM EVENT.
- ALL EROSION AND SEDIMENT CONTROL MEASURES SHALL BE PROTECTED FROM DAMAGE AT ALL TIMES. CONTROL MEASURES SHALL REMAIN IN PLACE UNTIL PERMANENT RE-VEGETATION HAS BEEN STABILIZED. ANY MEASURE THAT IS DAMAGED OR DESTROYED SHALL BE REPAIRED OR REPLACED IMMEDIATELY.
- ANY AREAS OF EXPOSED SOILS, INCLUDING ROADWAY EMBANKMENTS THAT WILL NOT BE DISTURBED FOR TWO DAYS DURING THE WET SEASON (OCTOBER 1 TO APRIL 30) OR SEVEN DAYS DURING THE DRY SEASON (MAY 1 TO SEPTEMBER 30) SHALL BE IMMEDIATELY STABILIZED WITH AN APPROVED ESC METHOD (SEEDING & MULCHING WITH STRAW, BARK, COMPOST, OR PLASTIC COVERING, ETC.).
- STREET SWEEPING SHALL BE PERFORMED AS NEEDED OR WHEN DIRECTED BY THE CITY INSPECTOR TO INSURE PUBLIC RIGHT-OF-WAYS ARE KEPT CLEAN AND FREE OF DEBRIS. STREET FLUSHING IS PROHIBITED.
- WHEN TRUCKING SATURATED SOILS FROM THE SITE, EITHER WATER-TIGHT TRUCKS SHALL BE USED OR LOADS SHALL BE DRAINED ON SITE UNTIL DRIPPING HAS BEEN REDUCED TO NO MORE THAN ONE GALLON PER HOUR. SEDIMENT LADEN WATER WILL NOT BE ALLOWED TO ENTER THE STORM WATER SYSTEM.
- EXTRACTED GROUND WATER FROM EXCAVATED TRENCHES SHALL BE DISPOSED OF IN A SUITABLE MANNER WITHOUT DAMAGE TO ADJACENT PROPERTY, CITY'S STORM WATER SYSTEM, WATER FEATURES, AND RELATED NATURAL RESOURCES. APPROVAL OF A DEWATERING SYSTEM DOES NOT GUARANTEE THAT IT WILL MEET COMPLIANCE OR BE ACCEPTABLE FOR USE IN ALL SITUATIONS. MODIFICATIONS TO THE DEWATERING SYSTEM WILL BE REQUIRED IF COMPLIANCE CAN NOT BE MET. AT NO TIME WILL SEDIMENT LADEN WATER BE ALLOWED TO LEAVE THE CONSTRUCTION SITE.
- A SUPPLY OF MATERIALS NECESSARY TO MEET COMPLIANCE AND IMPLEMENT THE LDAP OR OTHER BEST MANAGEMENT EROSION PRACTICES UNDER ALL WEATHER CONDITIONS SHALL BE MAINTAINED AT ALL TIMES ON THE CONSTRUCTION SITE.
- NO HAZARDOUS SUBSTANCES, SUCH AS PAINT, THINNERS, FUELS, AND OTHER CHEMICALS SHALL BE RELEASED ONTO THE SITE, ADJACENT PROPERTIES, OR INTO WATER FEATURES, THE CITY'S STORM WATER SYSTEM, OR RELATED RESOURCES.
- THE ESC FACILITIES SHALL BE INSPECTED DAILY BY THE CONTRACTOR AND MAINTAINED TO ENSURE CONTINUED PROPER FUNCTIONING. WRITTEN RECORDS SHALL BE KEPT OF WEEKLY REVIEWS OF THE ESC FACILITIES DURING THE WET SEASON (OCTOBER 1 TO APRIL 30) AND OF MONTHLY REVIEWS DURING THE DRY SEASON (MAY 1 TO SEPTEMBER 30).

EXISTING CONDITIONS

THE EXISTING PROJECT SITE IS COVERED IN DENSE GRASSES, BLACKBERRIES, VARIOUS SHRUBS, AND DECIDUOUS TREES.

PROPOSED CONDITIONS

THE SCOPE OF THE PROJECT CONSISTS OF MASS GRADING AND CONSTRUCTION FOR THE CHURCH OF LATTER-DAY SAINTS. THE PROJECT IS PROJECTED TO BEGIN OCTOBER OF 2017 AND CONSTRUCTION WILL CONTINUE FOR APPROXIMATELY TWELVE MONTHS.

SOIL TYPES

ACCORDING TO THE NATURAL RESOURCES CONSERVATION SERVICE SOIL WEB SURVEY WEBSITE MAPPING SERVICES, THE EXISTING SOILS ARE CHEHALIS SILTY CLAY LOAM (NRCS SOIL #26), CHEHALIS-URBAN LAND COMPLEX (NRCS SOIL #27), AND CLOQUATO SILT LOAM (NRCS SOIL #29).

DISTURBED AREA QUANTITIES

MOST OF THE CUT AND FILL NEEDED IS DUE TO THE STRIPPING OF ORGANIC TOPSOIL AND DEPTH OF EXCAVATION AND FILL REQUIRED FOR THE BUILDING PAD PER GEOTECHNICAL ENGINEER AND REPORT (PGS. 8-10)

TOTAL DISTURBED AREA = 2.10 ACRES

VOLUME DISTURBED AREA

CUT = 6,650 CUBIC YARDS

FILL = 3,500 CUBIC YARDS

TOTAL = 10,150 CUBIC YARDS

GRASS AND SEED NOTE

CONTRACTOR SHALL COORDINATE WITH OWNER AND OWNER'S REPRESENTATIVE WHEN SEEDING TO ESTABLISH VEGETATED COVER WHEN SPECIFIC CALLOUTS ARE NOT NOTED IN THE PLANS. SEED MIXES SHALL BE:

LAWN SEED: FUTURA 3000 BY PICKSEED, TANGENT, OREGON

ECO-LAWN SEED: ECO-LAWN MIX BY SUNMARK SEEDS INTERNATIONAL, INC.

EROSION CONTROL GRASS SEED: PRO-TIME 702 LOW PROFILE PLUS EROSION CONTROL MIX BY HOBBS AND HOPKINS, PORTLAND, OREGON

INSPECTION TABLE	
SITE CONDITION	MINIMUM FREQUENCY
1. ACTIVE PERIOD	DAILY WHEN STORMWATER RUNOFF, INCLUDING FROM SNOW MELT, IS OCCURRING. AT LEAST ONCE EVERY 14 DAYS, REGARDLESS OF WHETHER STORMWATER RUNOFF IS OCCURRING.
2. PRIOR TO THE SITE BECOMING INACTIVE OR IN ANTICIPATION OF SITE INACCESSIBILITY	ONCE TO ENSURE THAT EROSION AND SEDIMENT CONTROL MEASURES ARE IN WORKING ORDER. ANY NECESSARY MAINTENANCE AND REPAIR MUST BE MADE PRIOR TO LEAVING THE SITE.
3. INACTIVE PERIODS GREATER THAN FOURTEEN (14) CONSECUTIVE CALENDAR DAYS	ONCE EVERY MONTH.
4. PERIODS DURING WHICH THE SITE IS INACCESSIBLE DUE TO INCLEMENT WEATHER	IF PRACTICAL, INSPECTIONS MUST OCCUR DAILY AT A RELEVANT AND ACCESSIBLE DISCHARGE POINT OR DOWNSTREAM LOCATION.
5. PERIODS DURING WHICH DISCHARGE IS UNLIKELY DUE TO FROZEN CONDITIONS	MONTHLY; RESUME MONITORING IMMEDIATELY UPON MELT, OR WHEN WEATHER CONDITIONS MAKE DISCHARGE LIKELY.

date: SEPT. 25, 2017

drawn by: CM

designer: DG

project no: 16-146

LDAP COVER SHEET AND NOTES

sheet:

LDAP 1

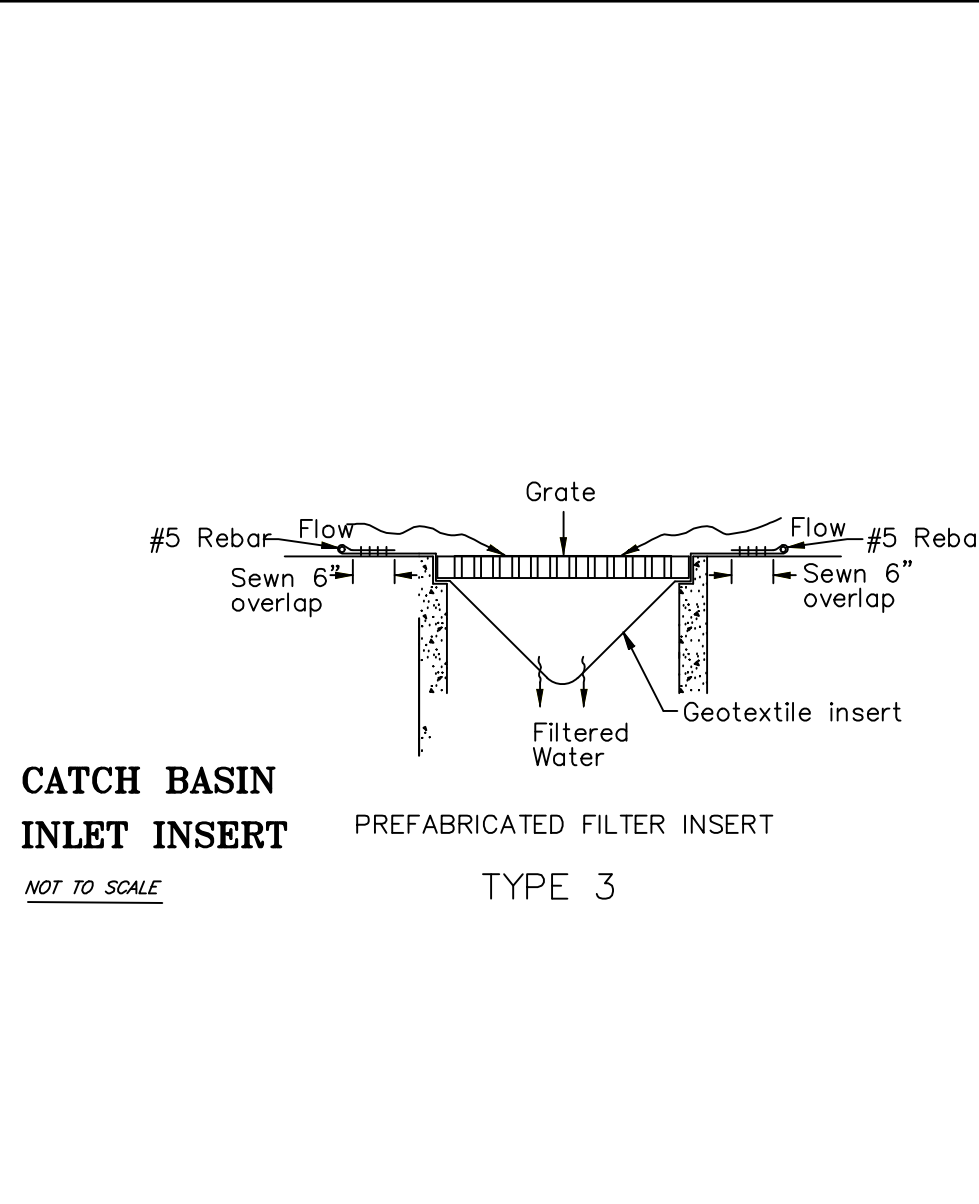

CATCH BASIN INLET INSERT
 PREFABRICATED FILTER INSERT
 TYPE 3
 NOT TO SCALE

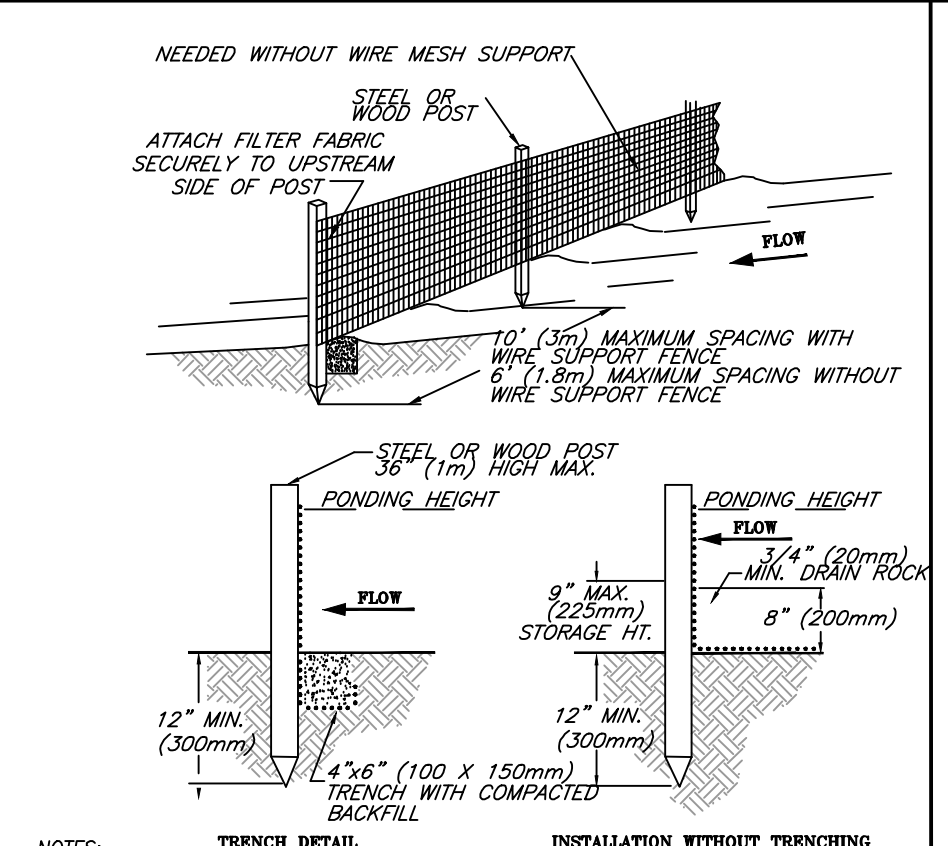

SILT FENCE
 NOT TO SCALE

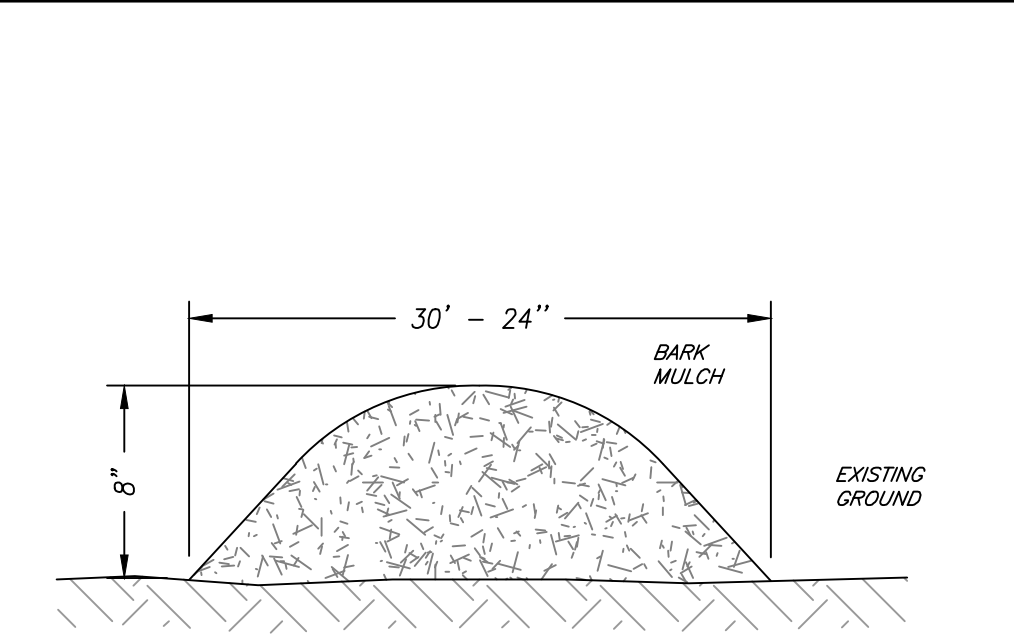

BARK BERM
 NOT TO SCALE

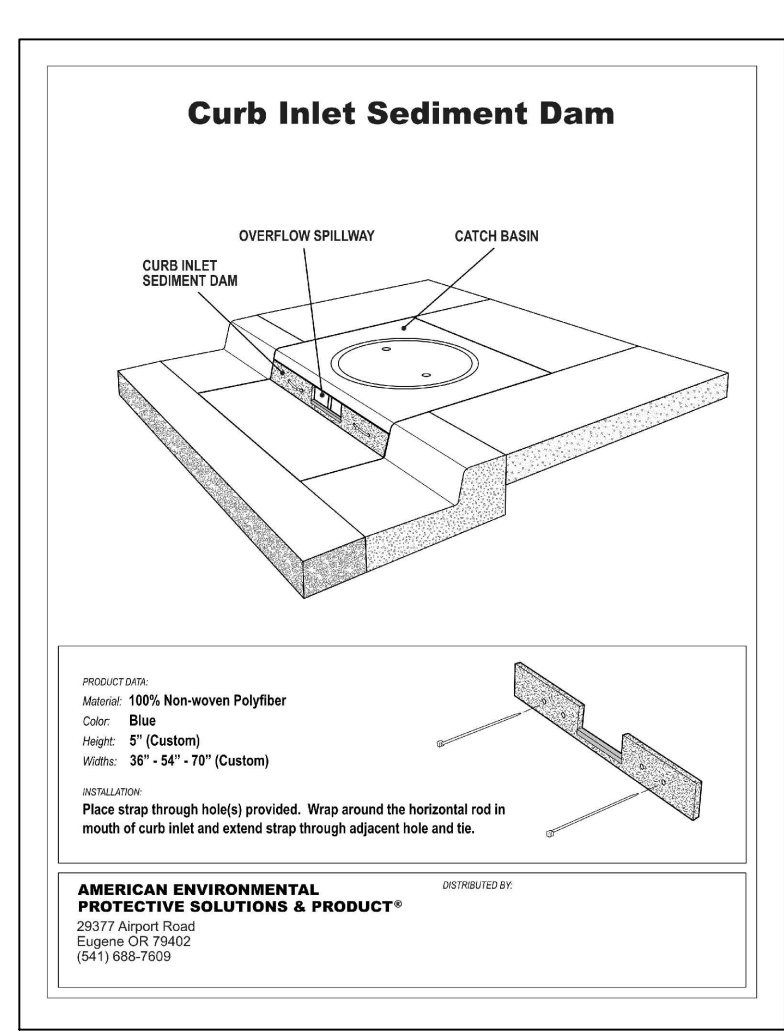

CURB INLET SEDIMENT DAM
 NOT TO SCALE

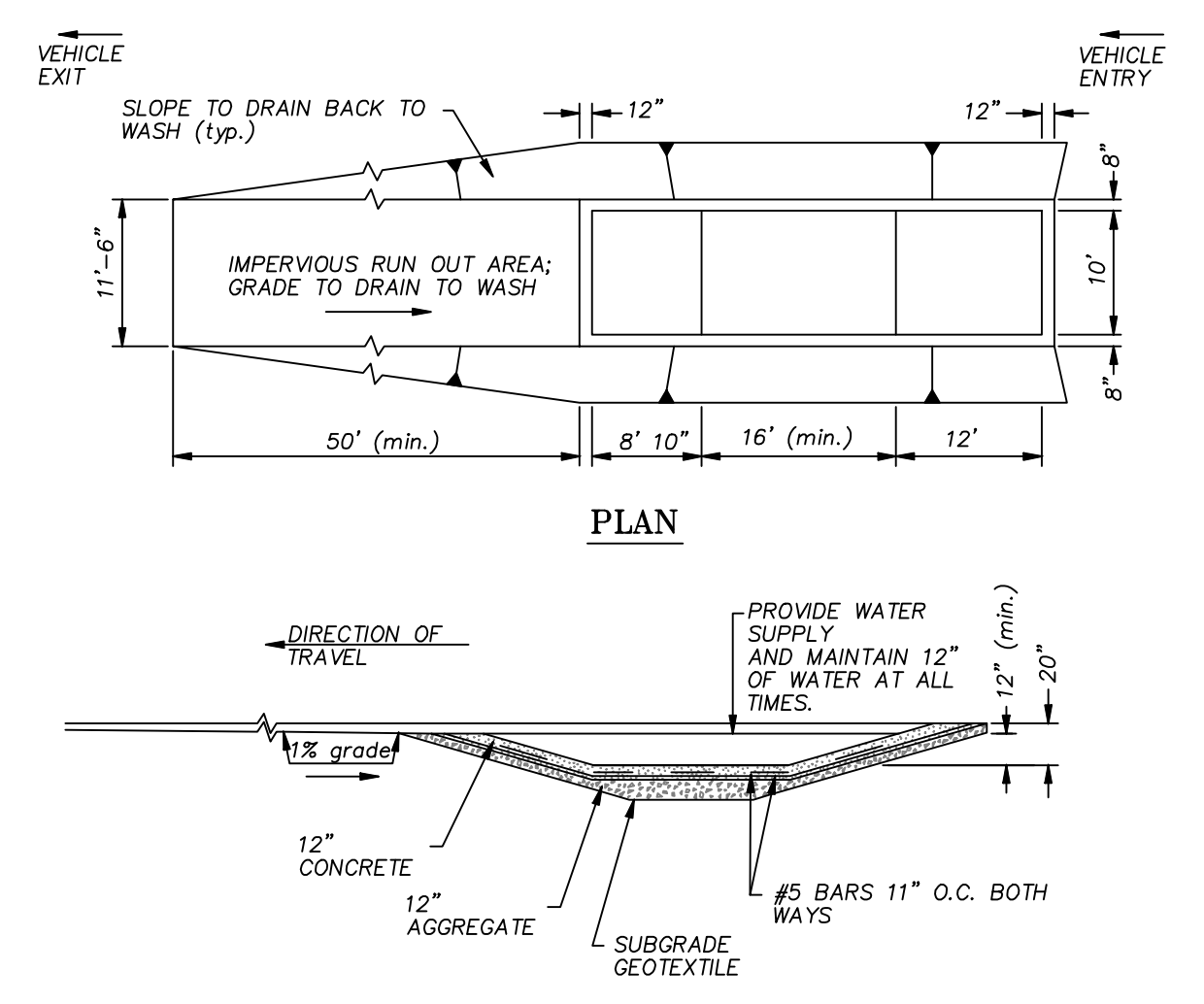

WHEEL WASH
 NOT TO SCALE

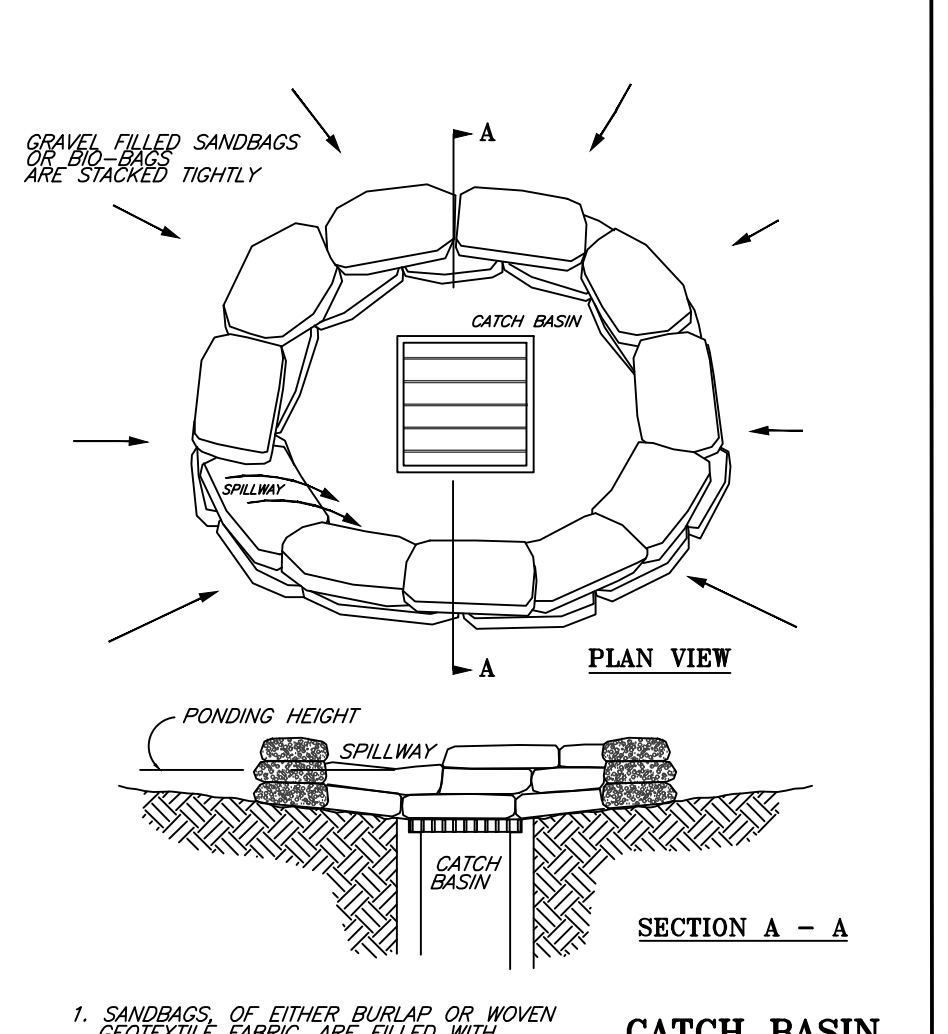

CATCH BASIN SEDIMENT BARRIER
 NOT TO SCALE

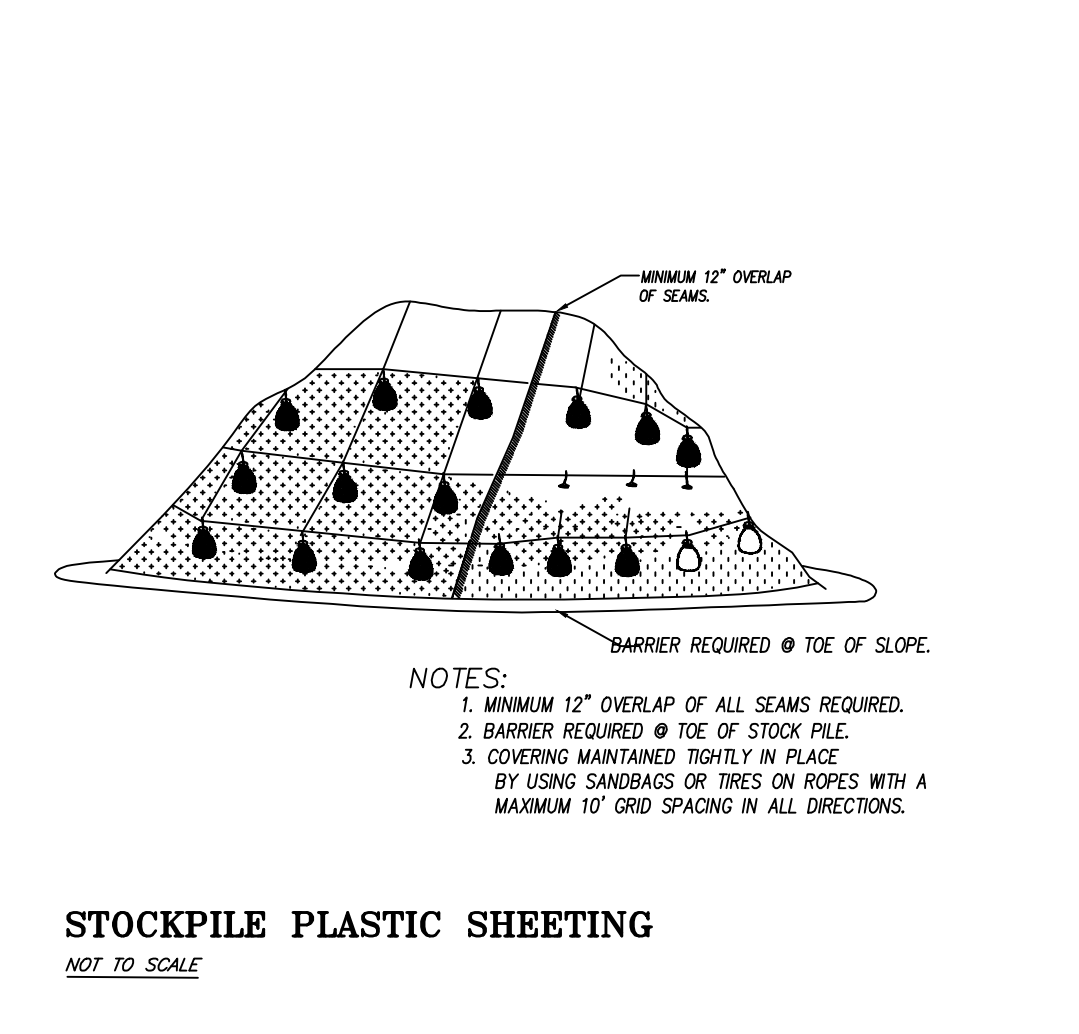

STOCKPILE PLASTIC SHEETING
 NOT TO SCALE

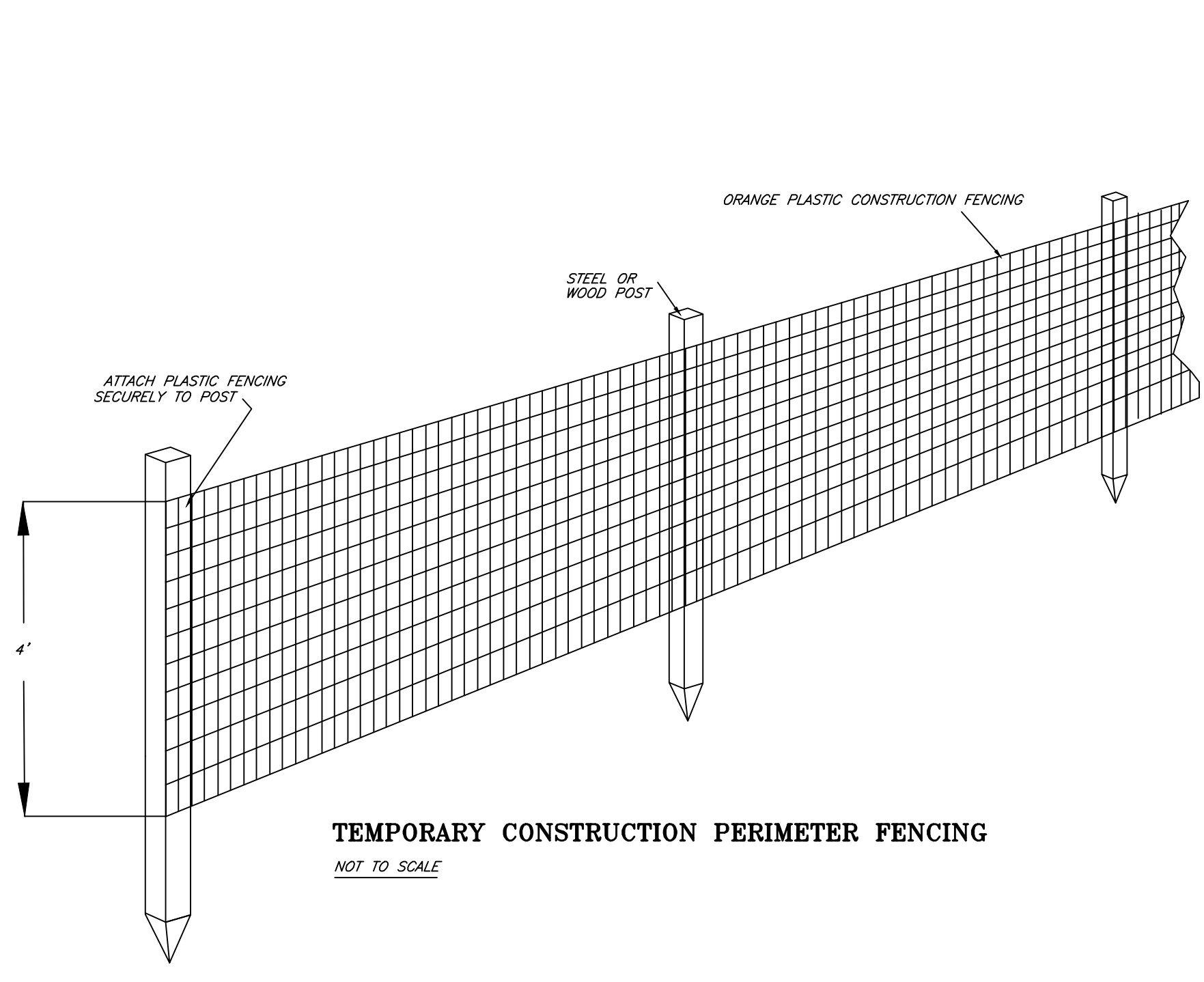

TEMPORARY CONSTRUCTION PERIMETER FENCING
 NOT TO SCALE

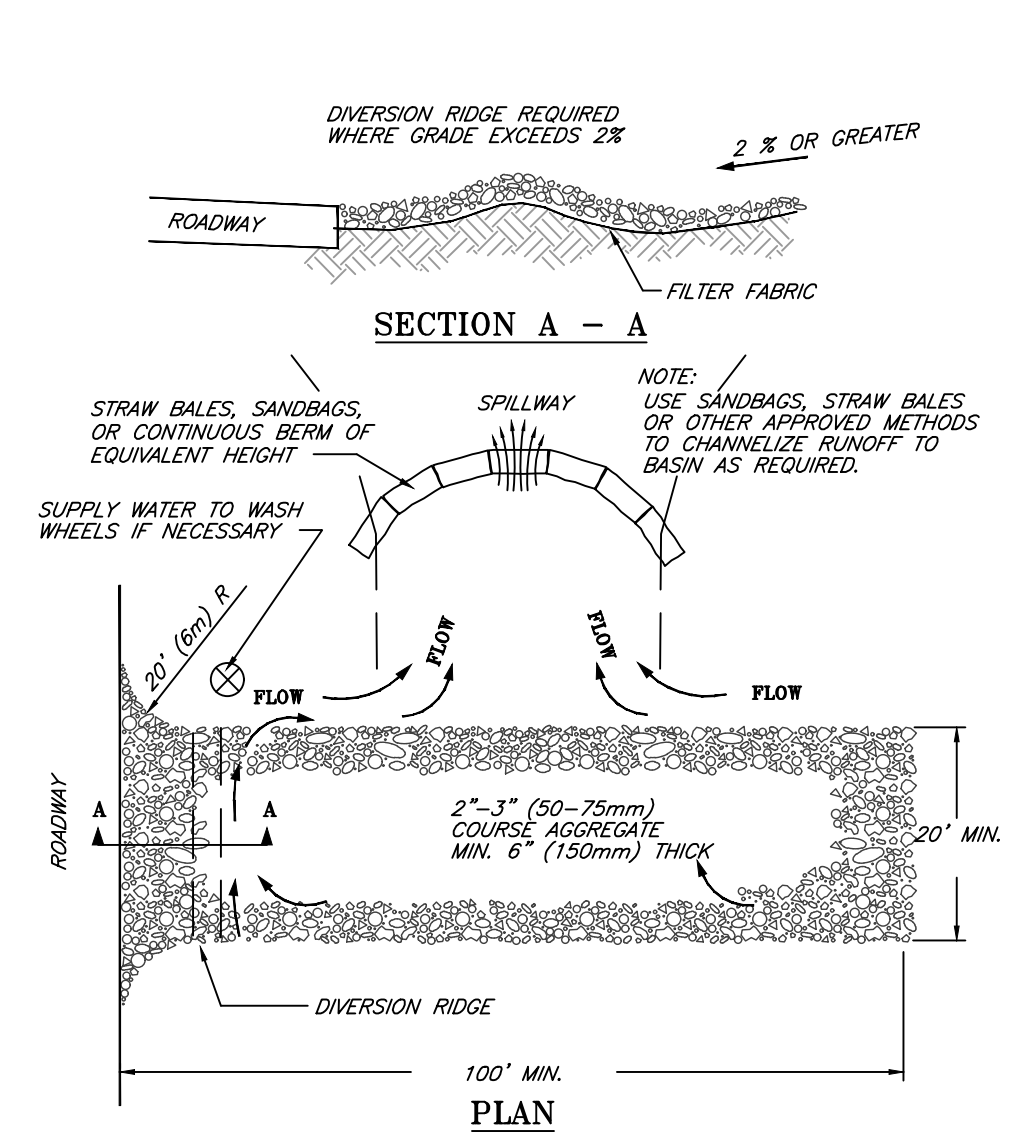

TEMPORARY GRAVEL CONSTRUCTION ENTRANCE/EXIT
 NOT TO SCALE

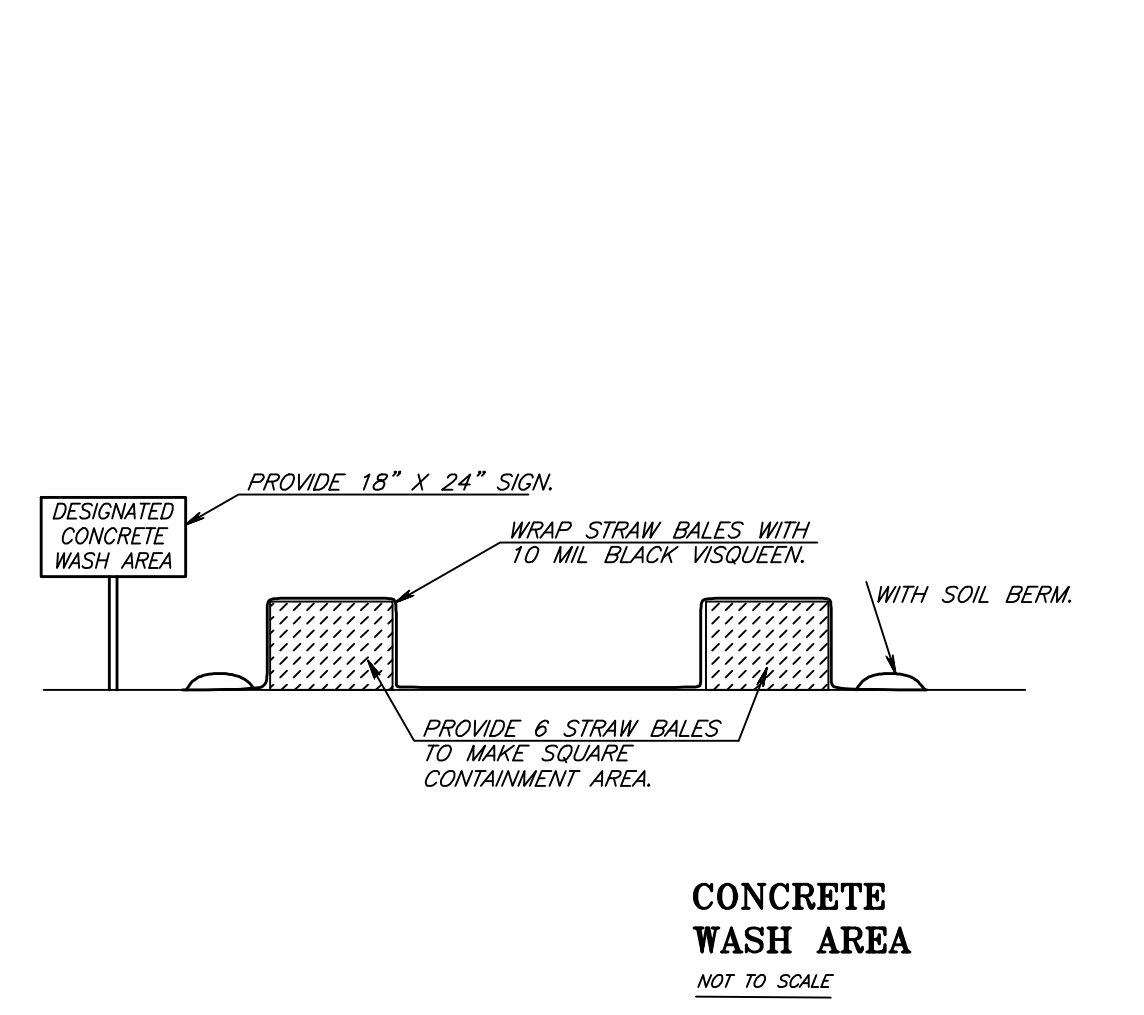

CONCRETE WASH AREA
 NOT TO SCALE

CONSTRUCTION NOTES

- ① INSTALL CATCH BASIN INLET INSERT PER DETAIL SHEET LDAP 3.
- ② CONSTRUCT SEDIMENT FENCE, BARK BERM OR APPROVED ALTERNATIVE FILTER MEDIA PER DETAIL SHEET LDAP 3.
- ③ INSTALL ORANGE CONSTRUCTION FENCING AROUND SITE, TREES AND AREAS TO BE PROTECTED PER DETAIL SHEET LDAP 3.
- ④ CONSTRUCT CONCRETE TRUCK WASHOUT PER DETAIL ON SHEET LDAP 3.
- ⑤ MINIMIZE CONSTRUCTION ACTIVITY IN THOSE AREAS DESIGNATED FOR STORMWATER TREATMENT AND INFILTRATION.
- ⑥ LOCATION FOR STOCKPILE AREA. FINAL LOCATION TO BE SELECTED BY CONTRACTOR AND APPROVED BY CITY. STRIP EXISTING TOP SOIL UNDER STOCKPILE. COVER STOCKPILE WITH PLASTIC SHEETING PER DETAIL LDAP 3.
- ⑦ SUGGESTED LOCATION FOR STAGING AREAS. FINAL LOCATIONS TO BE SELECTED BY CONTRACTOR.
- ⑧ INSTALL BIO-BAG SEDIMENT BARRIER AROUND CATCH BASIN PER DETAIL ON SHEET LDAP 3.
- ⑨ CONSTRUCT GRAVEL CONSTRUCTION ENTRANCE PER DETAIL ON SHEET LDAP 3.
- ⑩ CONSTRUCT WHEEL WAS STATION FOR USE DURING WET WEATHER CONSTRUCTION PER DETAIL SHEET LDAP 3.
- ⑪ INSTALL CURB INLET SEDIMENT DAM PER DETAIL SHEET LDAP 3.

CONSTRUCTION SEQUENCE SCHEDULE

- A. SUBSTANTIAL COMPLETION PROJECT - OCTOBER 2017 THRU SEPTEMBER 2018 (WORK COMPLETED BY AGENT OF OWNER.)
1. SUBSTANTIAL COMPLETION OF EARTHWORK - 4 TO 6 WEEKS AFTER CONSTRUCTION BEGINS.
 2. SUBSTANTIAL COMPLETION OF UTILITIES INSTALLATION - 2 TO 4 WEEKS AFTER COMPLETION OF EARTHWORK.
 3. SUBSTANTIAL COMPLETION OF STORMWATER POND - 2 TO 3 WEEKS AFTER COMPLETION OF UTILITIES INSTALLATION.
 4. SUBSTANTIAL COMPLETION OF DRIVE AND PARKING AREA PAVING AND CONCRETE WORK - 3 TO 5 WEEKS AFTER COMPLETION OF STORMWATER POND.
 5. SUBSTANTIAL COMPLETION OF STRUCTURAL WORK - 18-30 WEEKS AFTER COMPLETION OF STORMWATER POND.
 6. SUBSTANTIAL COMPLETION OF TREE PLANTING, LANDSCAPING AND LIGHTING - 2-4 WEEKS AFTER COMPLETION OF STRUCTURAL WORK.
 7. CLEANUP AND REMOVAL OF EROSION AND SEDIMENT BMPs - 2-4 WEEKS
- B. PROJECT FINAL COMPLETION: SEPTEMBER 30, 2018.
- * ADDITIONAL COORDINATION WILL NEED TO OCCUR BETWEEN THE CONTRACTOR, THE ENGINEER, AND CITY INSPECTORS AS CONSTRUCTION STAGING, SEQUENCING, AND SCHEDULING BECOME MORE REFINED. MORE TEMPORARY EROSION CONTROL MEASURES BEYOND THOSE NOTED MAY BE NECESSARY DEPENDING ON CONTRACTOR'S METHODOLOGY.

LEGEND

- LIMITS OF DISTURBANCE
- PROPOSED STAGING AREA
- PROPOSED SEDIMENT FENCE OR BERM
- CONSTRUCTION FENCING
- PROPOSED STOCKPILE AREA
- PROPOSED CONCRETE WASHOUT
- GRAVEL CONSTRUCTION ENTRANCE
- CATCH BASIN INLET INSERT
- WHEEL WASH STATION
- BIOBAG FILTERS
- EXISTING ELEVATION
- PROPOSED ELEVATION
- CURB INLET SEDIMENT DAM

